

ARMADO FÁCIL

MODELO AF2-02

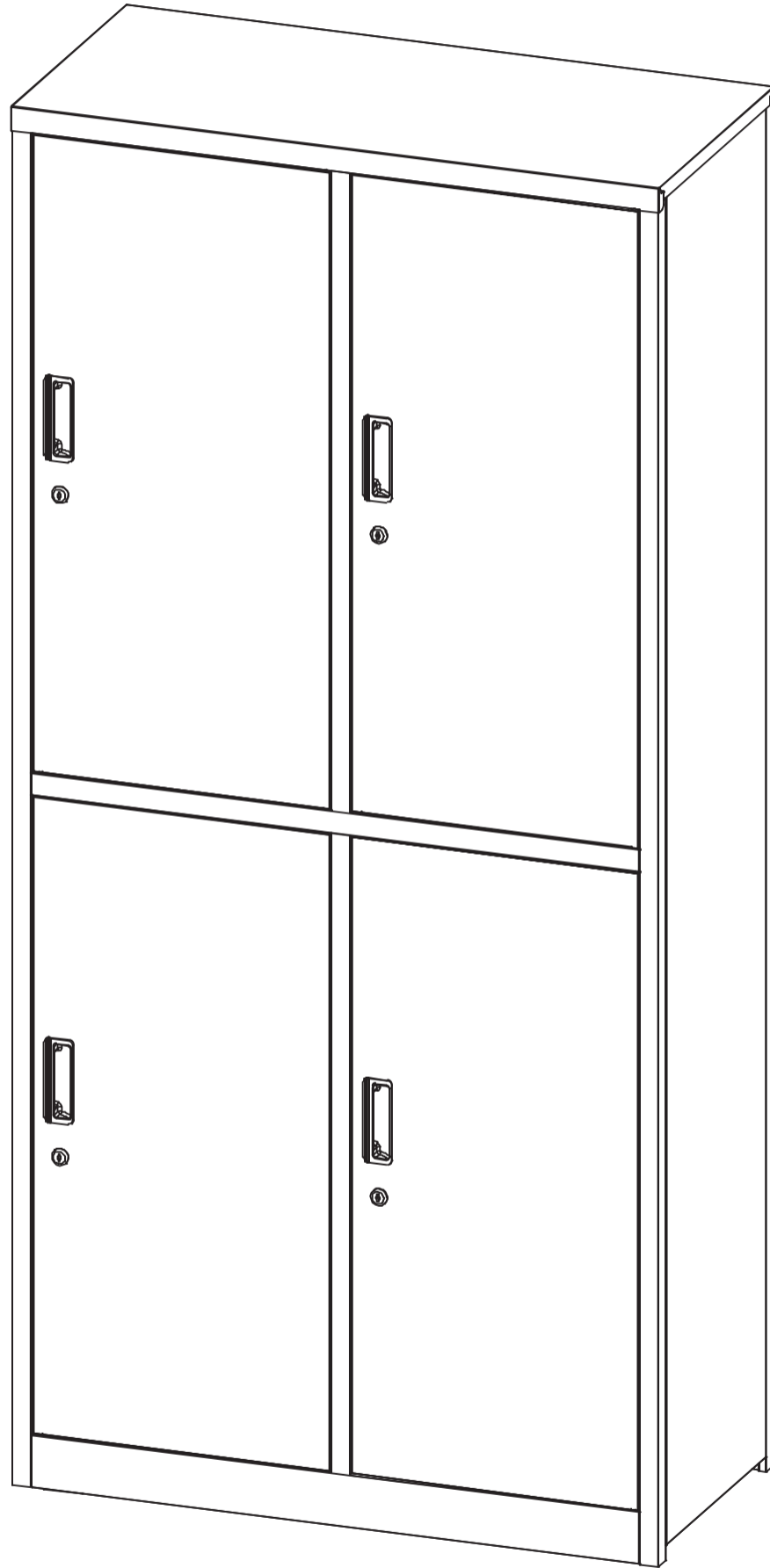

Herramientas necesarias:

**Atornillador de Cruz
(no incluido)**

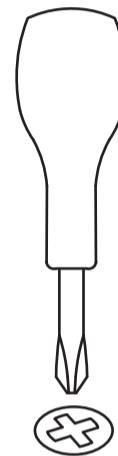

¡Precaución!

Para evitar volcamiento del mueble no debe sobrecargarse en bandejas/compartimentos superiores.

Para evitar volcamiento puede fijarse a la pared (no se incluyen herramientas ni tornillos de fijación).

Este mueble debe ser armado por un adulto. En caso de duda, busca asesoramiento profesional. Lee y sigue cada paso de las instrucciones cuidadosamente.

ARMADO FÁCIL LISTA DE COMPONENTES

Tapa Superior (x1)



Tapa Central (x1)
Con ranura en bandeja



Tapa Inferior (x1)
Con ranura en bandeja



Bandejas

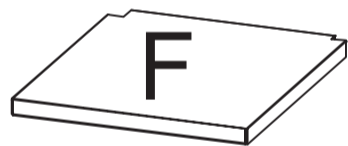

Izquierda
(Grande)
x2

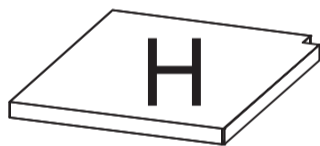

Derecha
x2

Barras

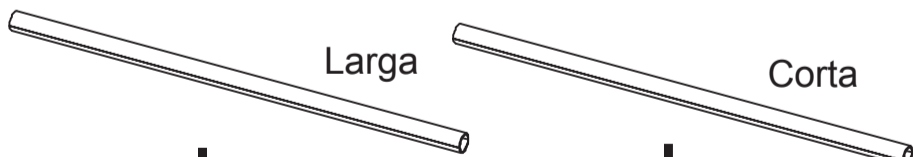

I x2

J x2

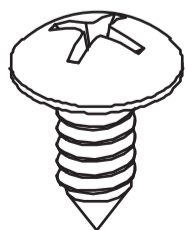

x12
Tornillo "A"

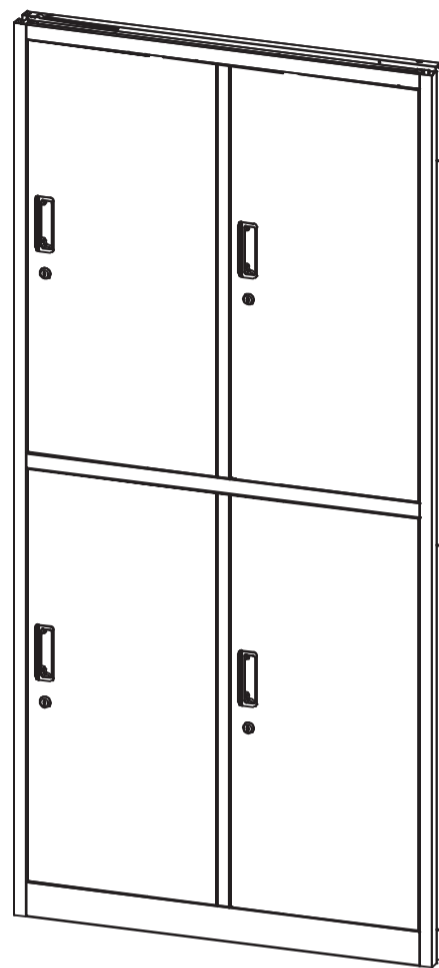

x1

Soporte
pie de altura

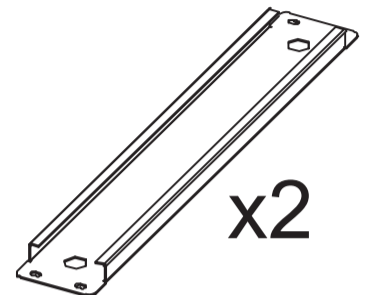

x8
Tornillo "B"

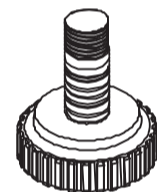

x4

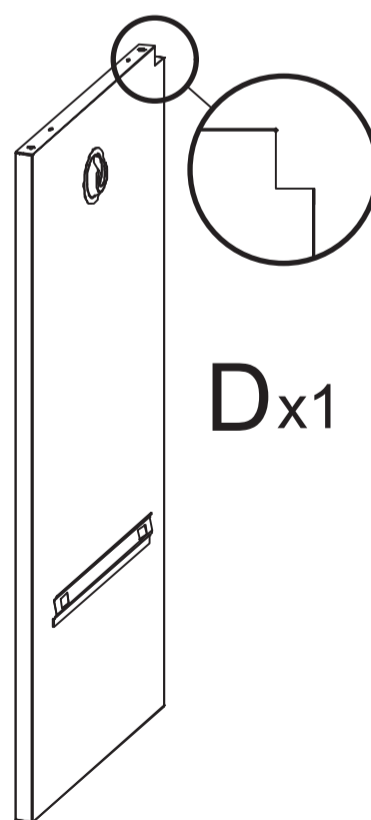

D x1

Placa vertical
superior (corta)

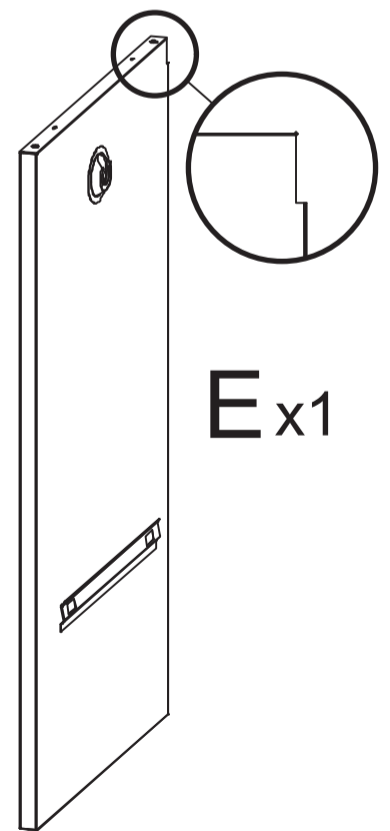

E x1

Placa vertical
inferior (larga)

ARMADO FÁCIL PASO 1 · APERTURA



ARMADO FÁCIL PASO 2 · FIJACIÓN BASE

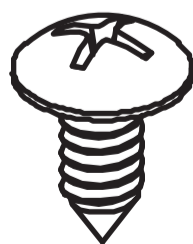
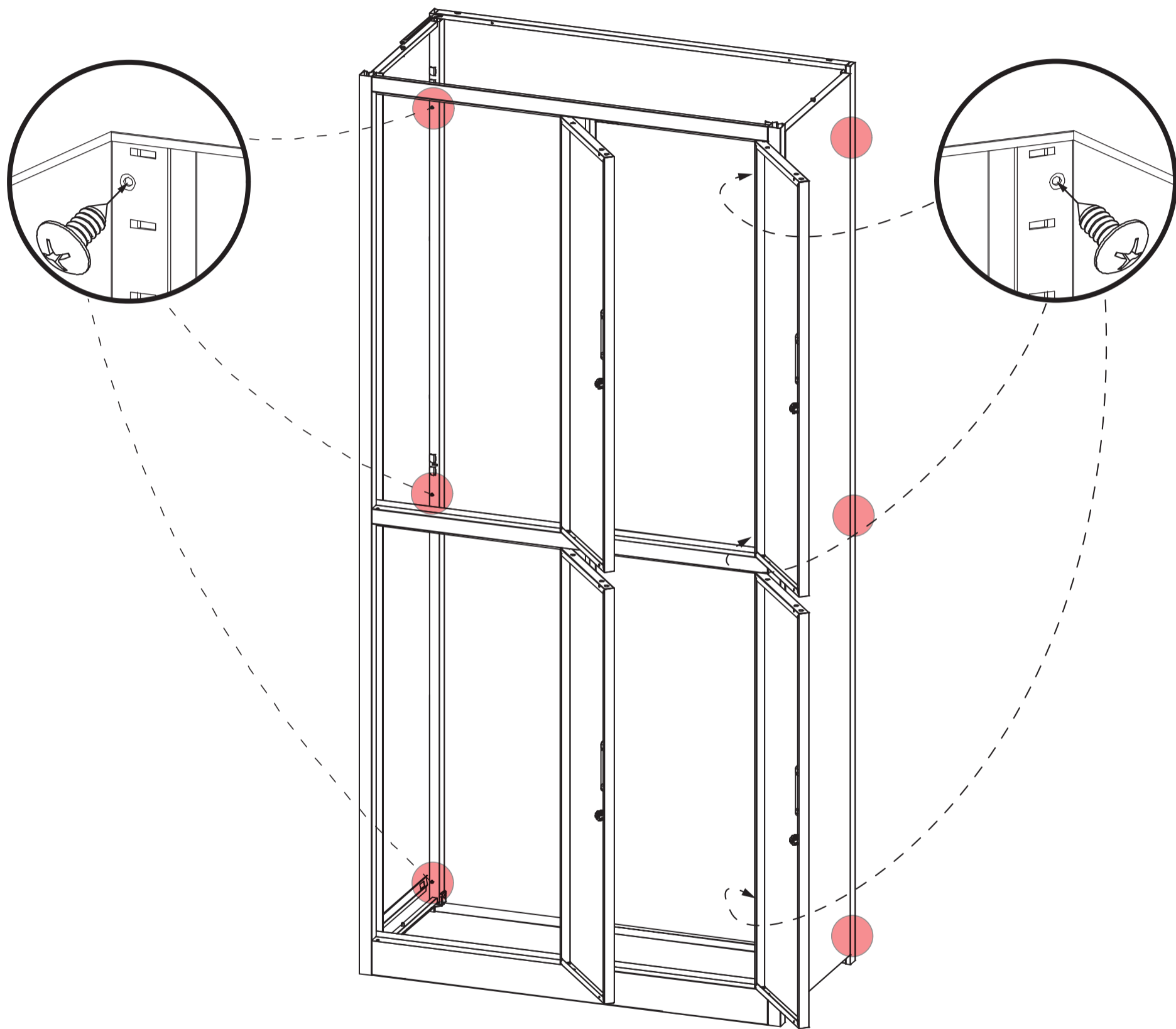

x6
Tornillo "A"

ARMADO FÁCIL PASO 3 · TAPAS CENTRAL E INFERIOR

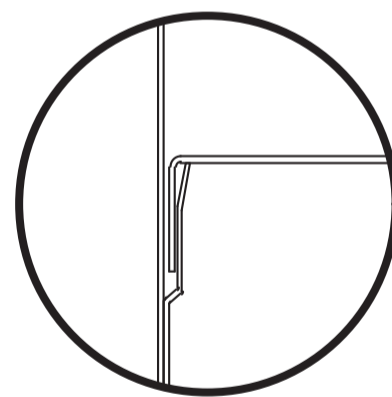
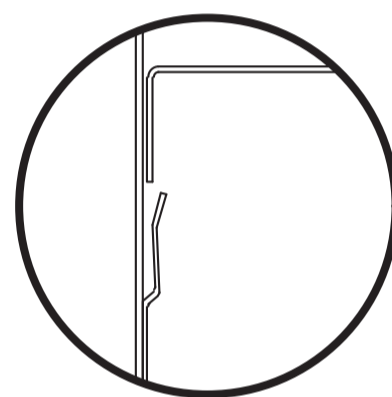
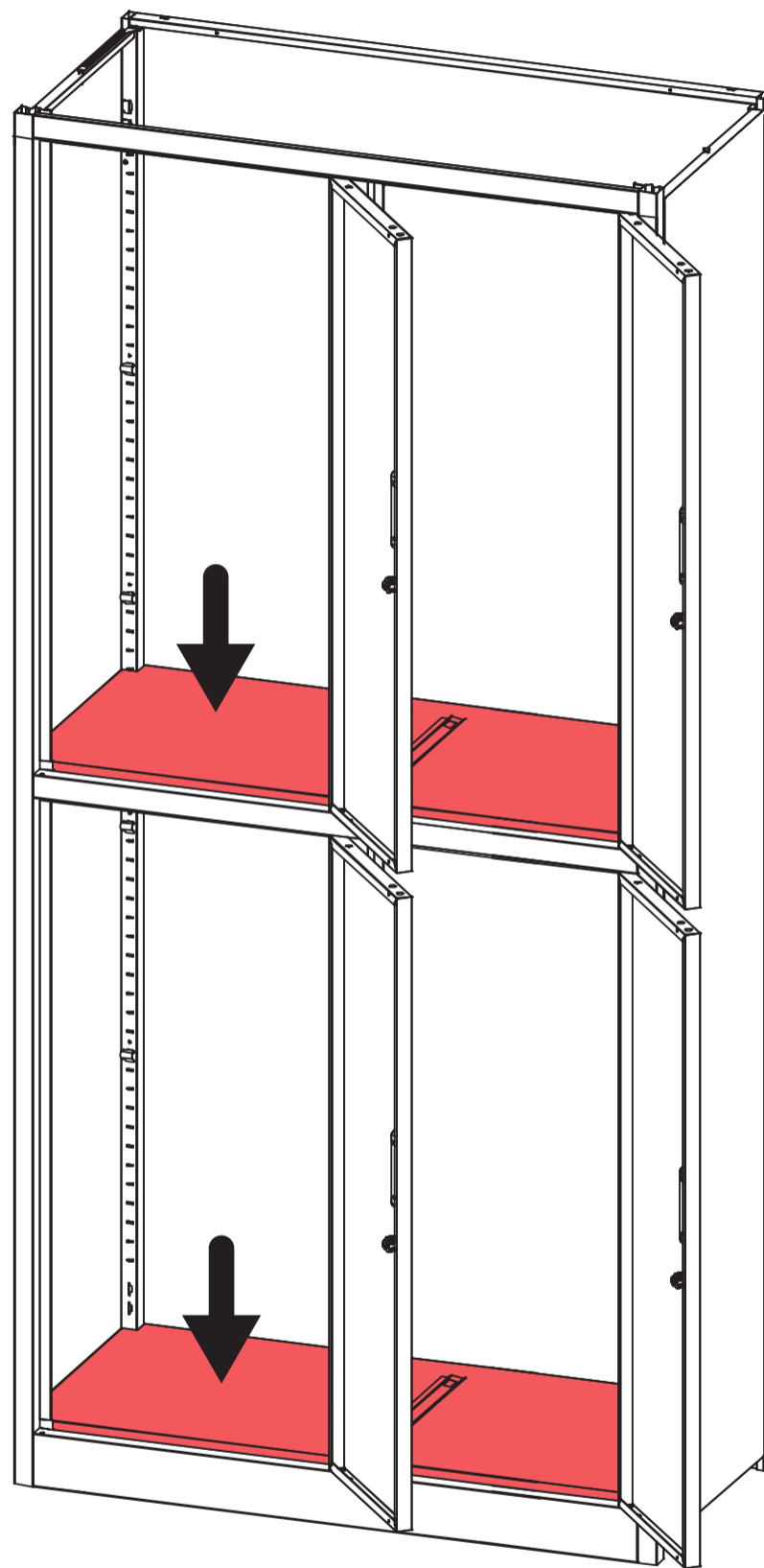

Enganche
atrás y costados

ARMADO FÁCIL PASO 4 · TAPA SUPERIOR

Tapa Superior A

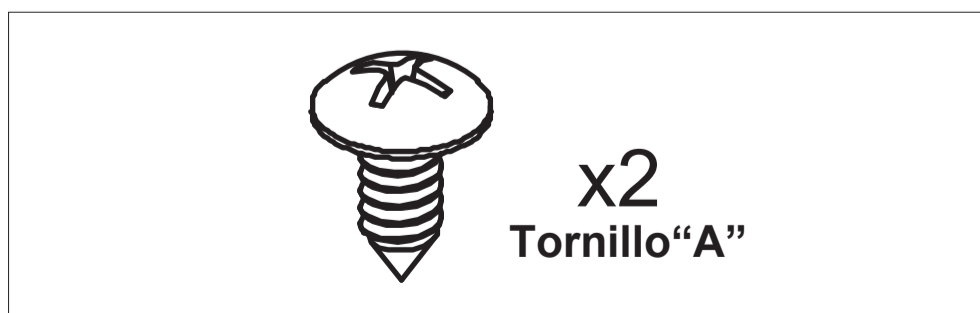
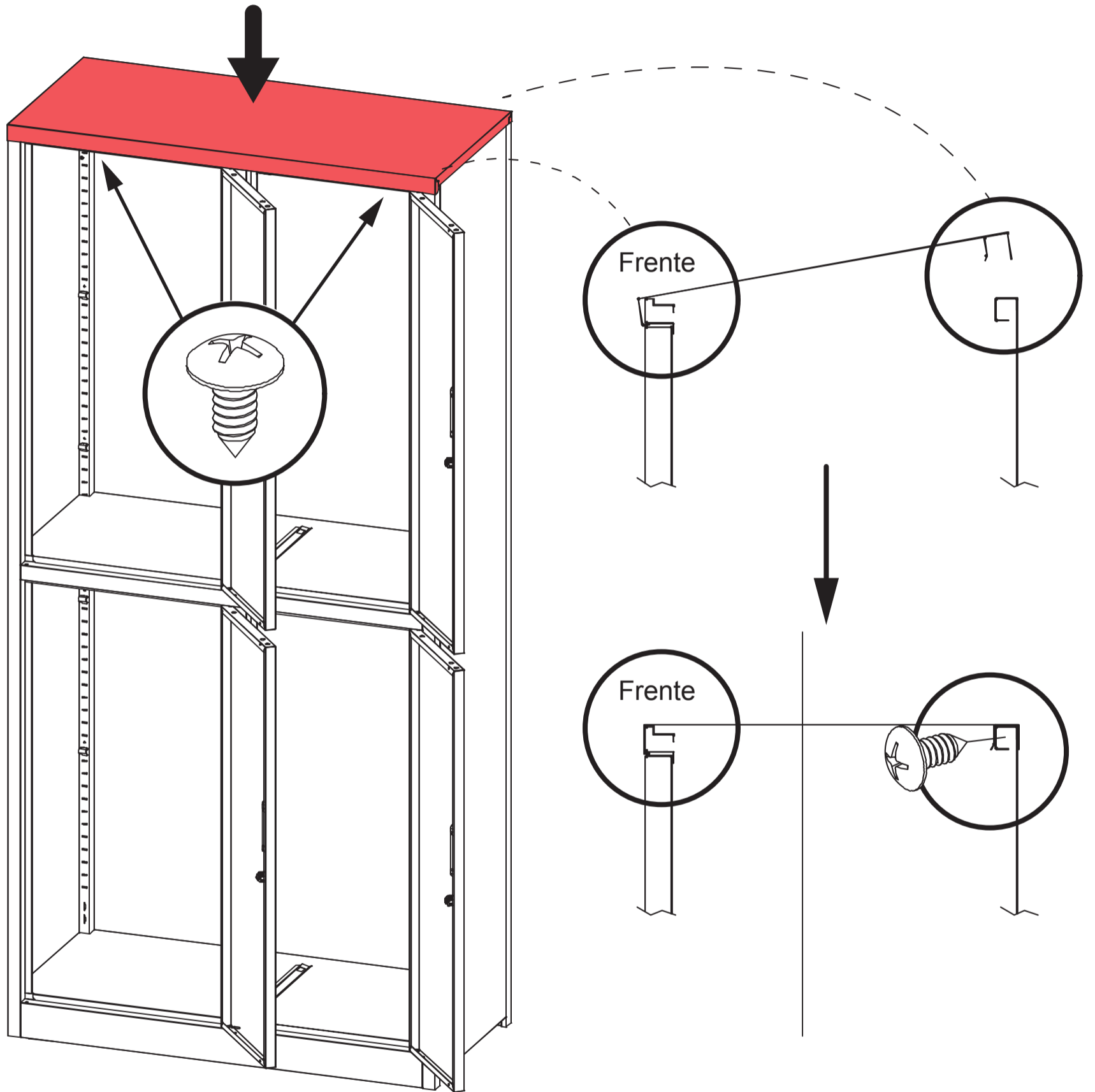

ARMADO FÁCIL PASO 5 · SEPARACIÓN VERTICAL

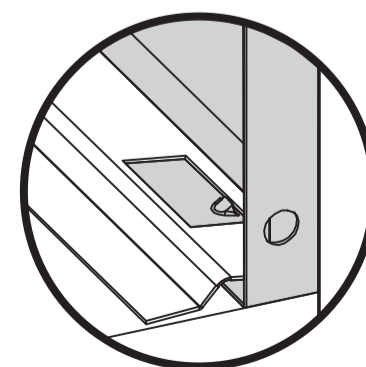
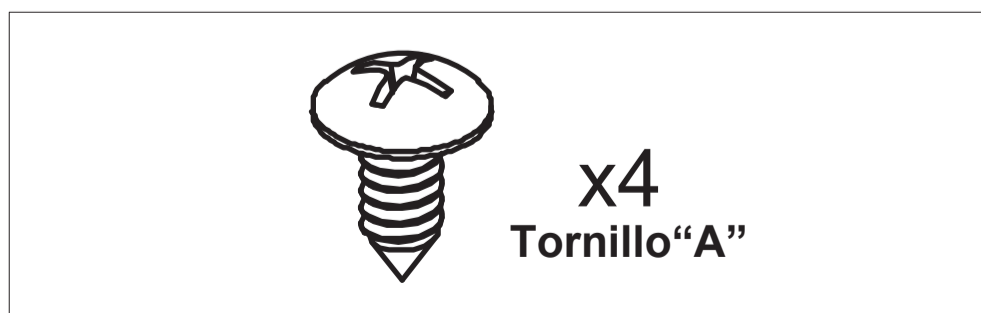
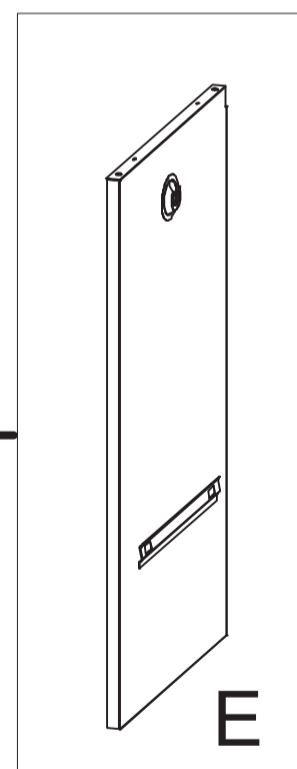
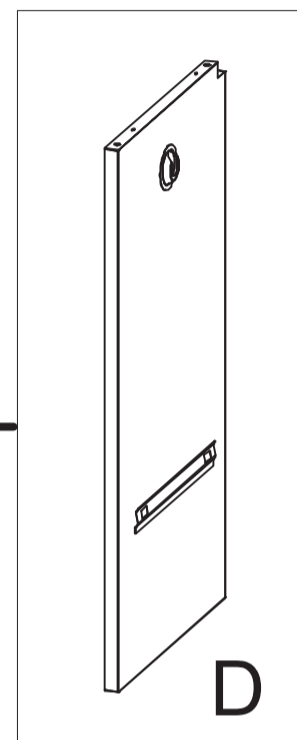
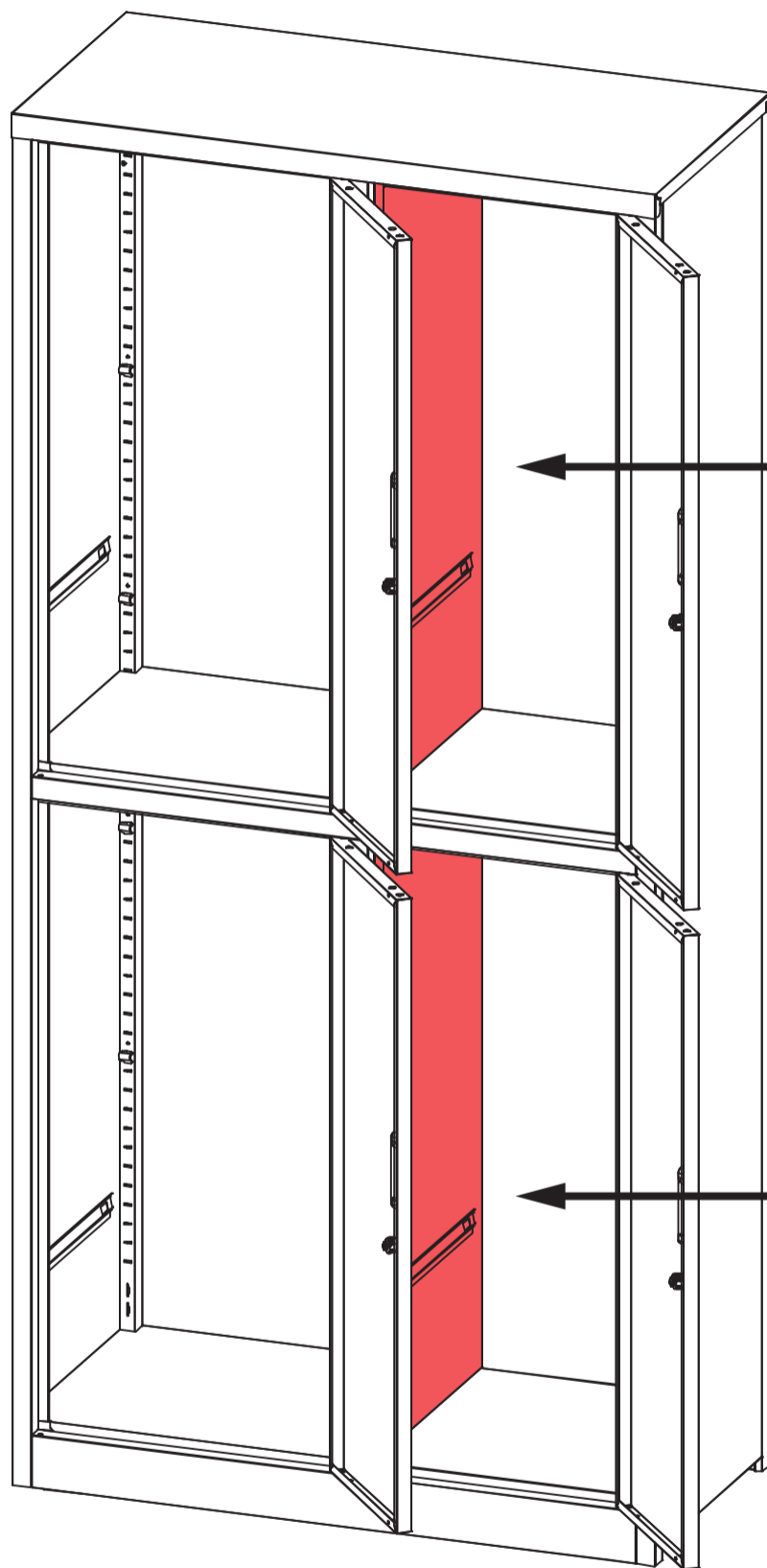
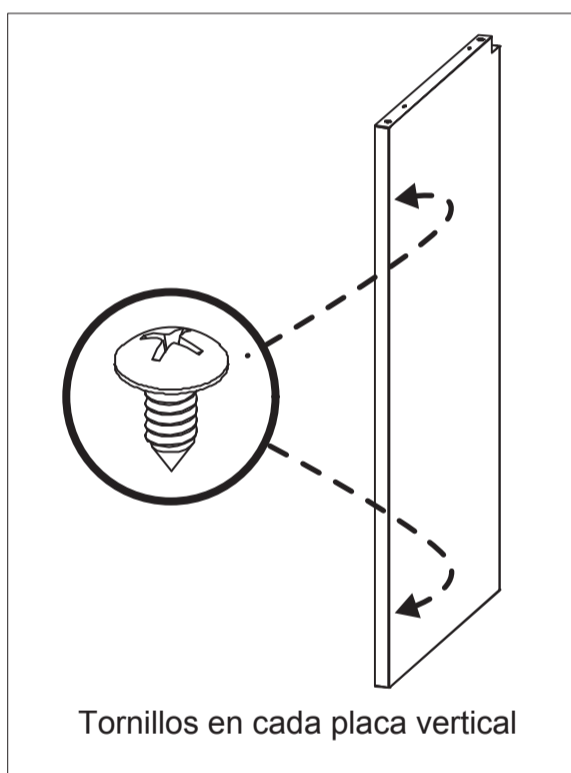

Enganche superior e inferior de cada placa vertical

ARMADO FÁCIL PASO 6 · BARRAS Y BANDEJAS

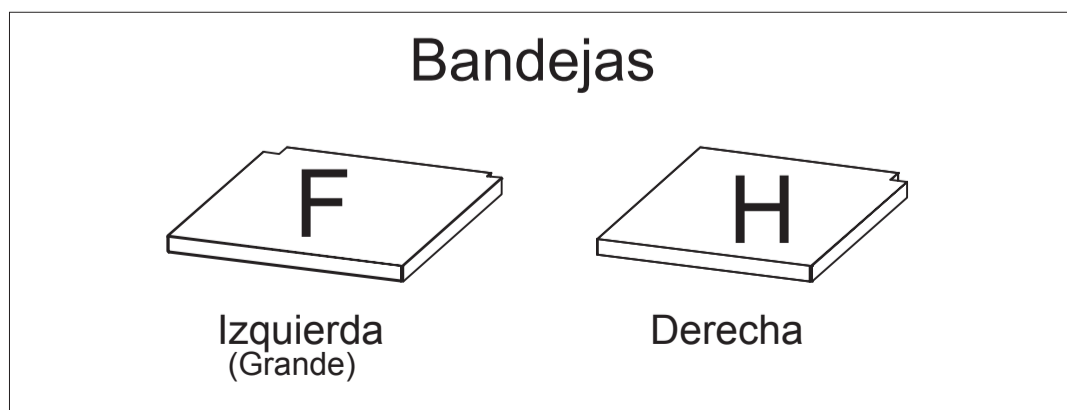
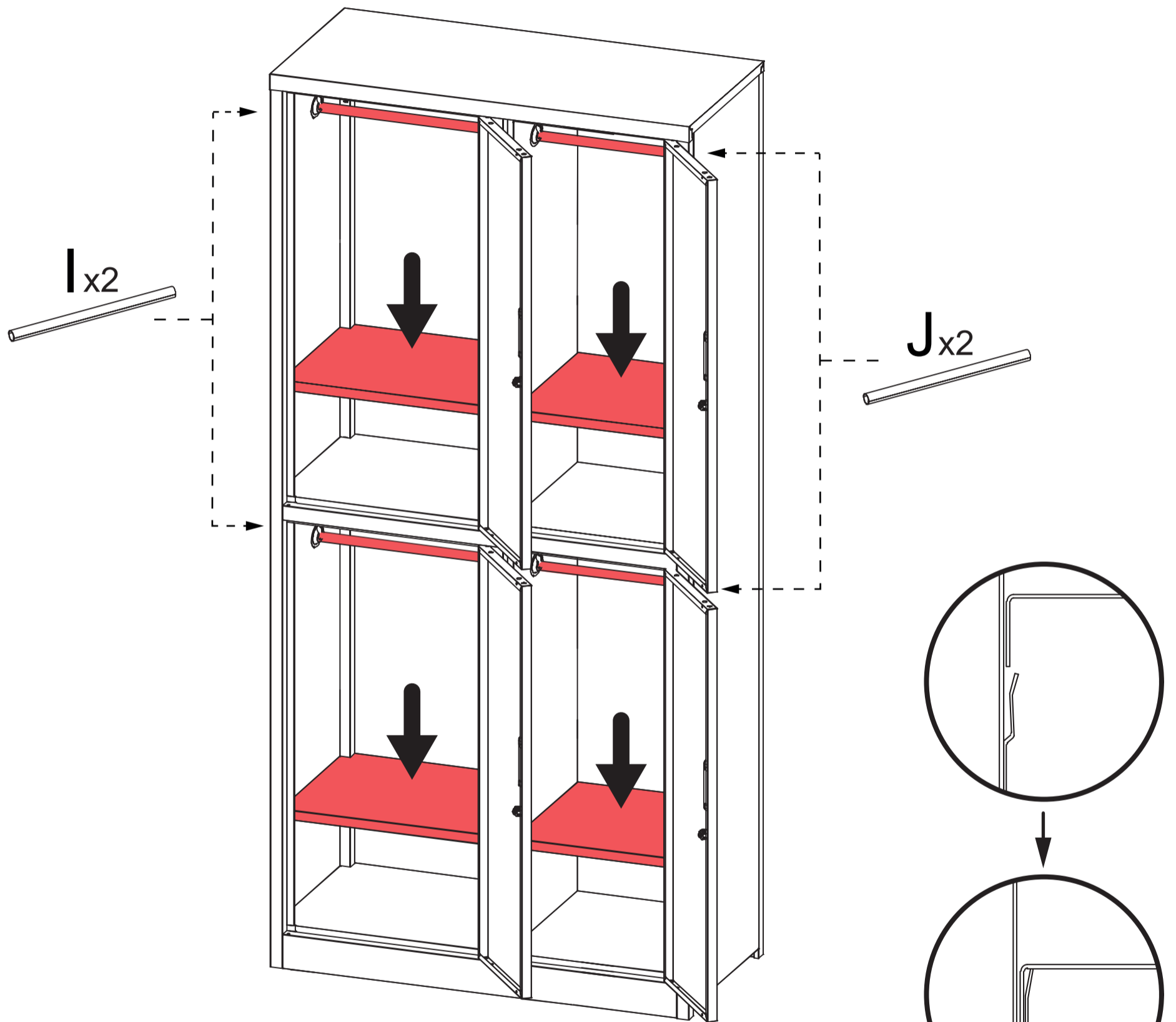

ARMADO FÁCIL PASO 7 · SOPORTE PIE DE ALTURA

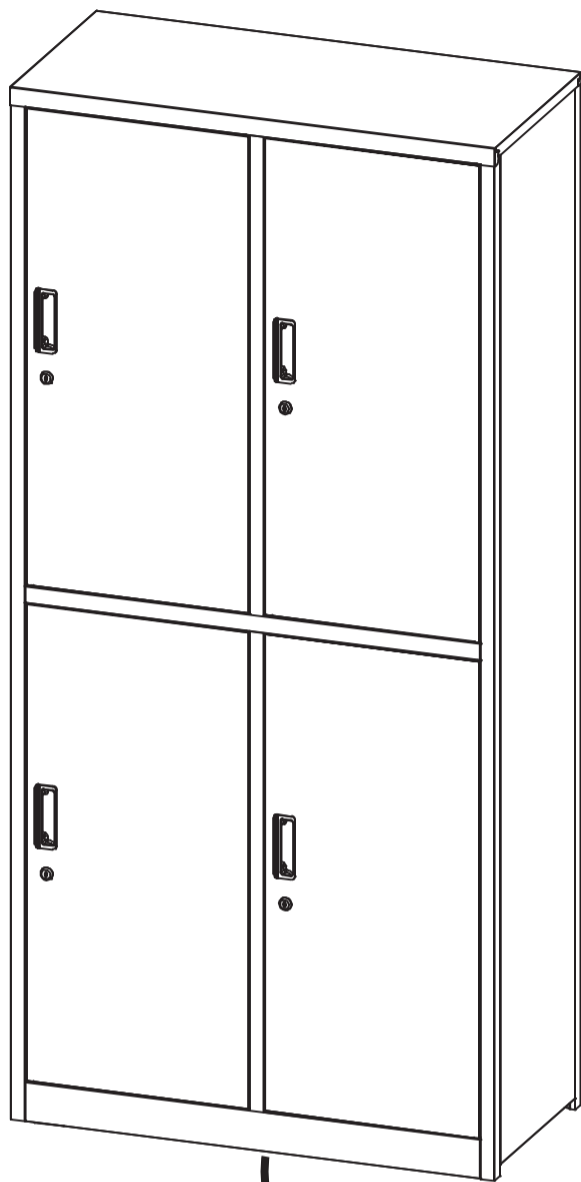

Zona Inferior

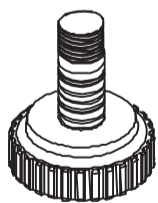
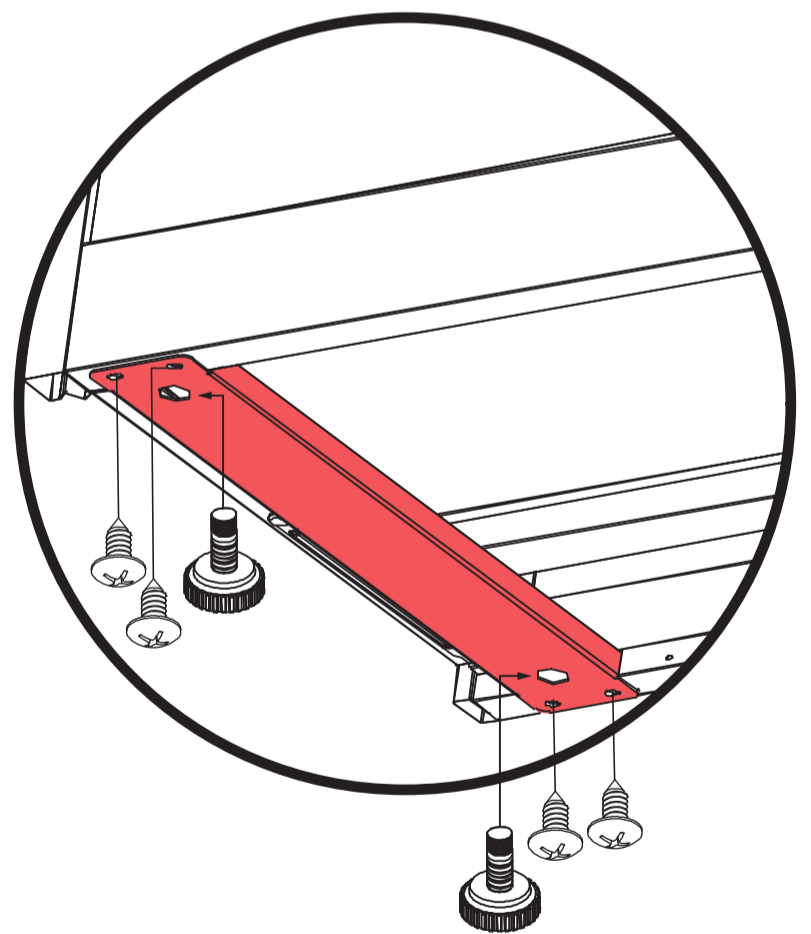

x4

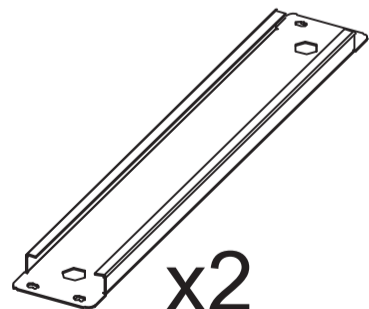

x2

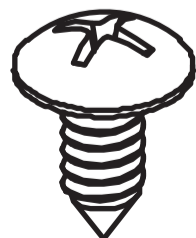

x8
Tornillo "B"

ARMADO FÁCIL

