

ARMADO FÁCIL

MODELO AF3-01



Herramientas necesarias:

**Atornillador de Cruz
(no incluido)**

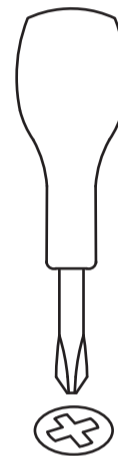

¡Precaución!

Para evitar volcamiento del mueble no debe sobrecargarse en bandejas/compartimentos superiores.

Para evitar volcamiento puede fijarse a la pared (no se incluyen herramientas ni tornillos de fijación).

Este mueble debe ser armado por un adulto. En caso de duda, busca asesoramiento profesional. Lee y sigue cada paso de las instrucciones cuidadosamente.

ARMADO FÁCIL LISTA DE COMPONENTES

Tapa Superior (x1)



Tapa Inferior (x1)
Con ranuras en bandeja

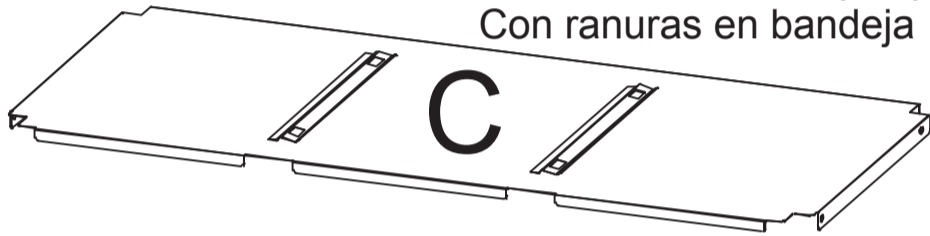

Bandejas

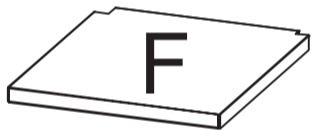

Izquierda
x1



Centro
x1

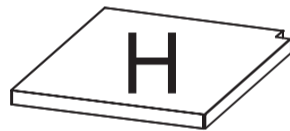

Derecha
x1

Barras

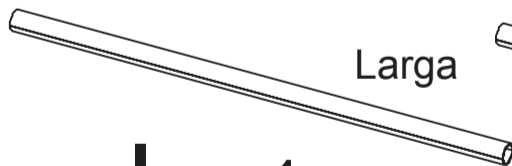

x1

Larga



x2

Corta

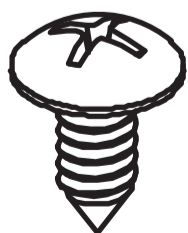

x14
Tornillo "A"

B

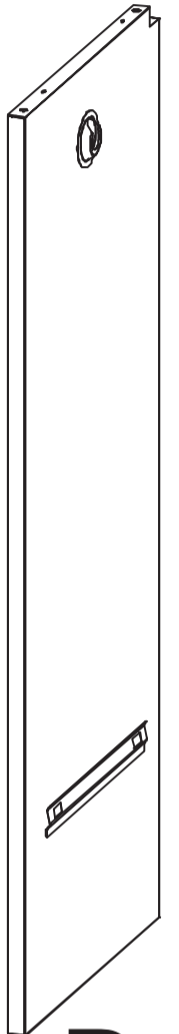
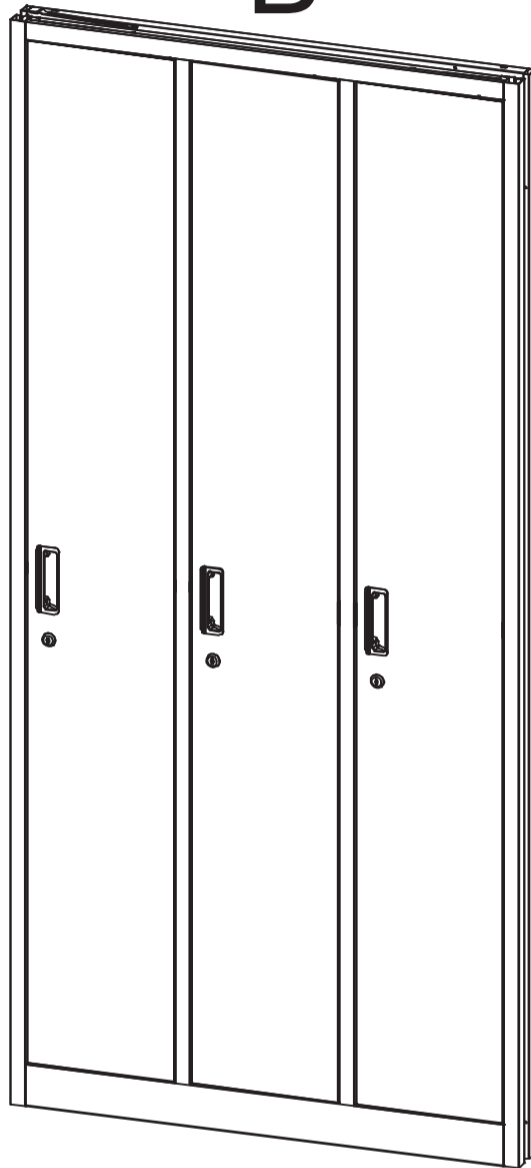

x2

Soporte pie de altura

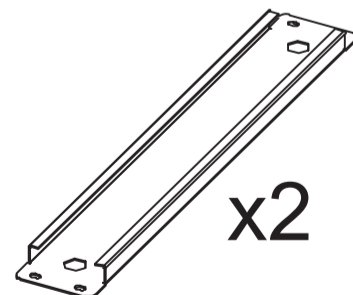

x2

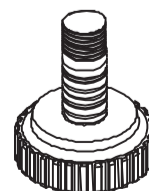

x4



x8
Tornillo "B"

ARMADO FÁCIL PASO 1 · APERTURA

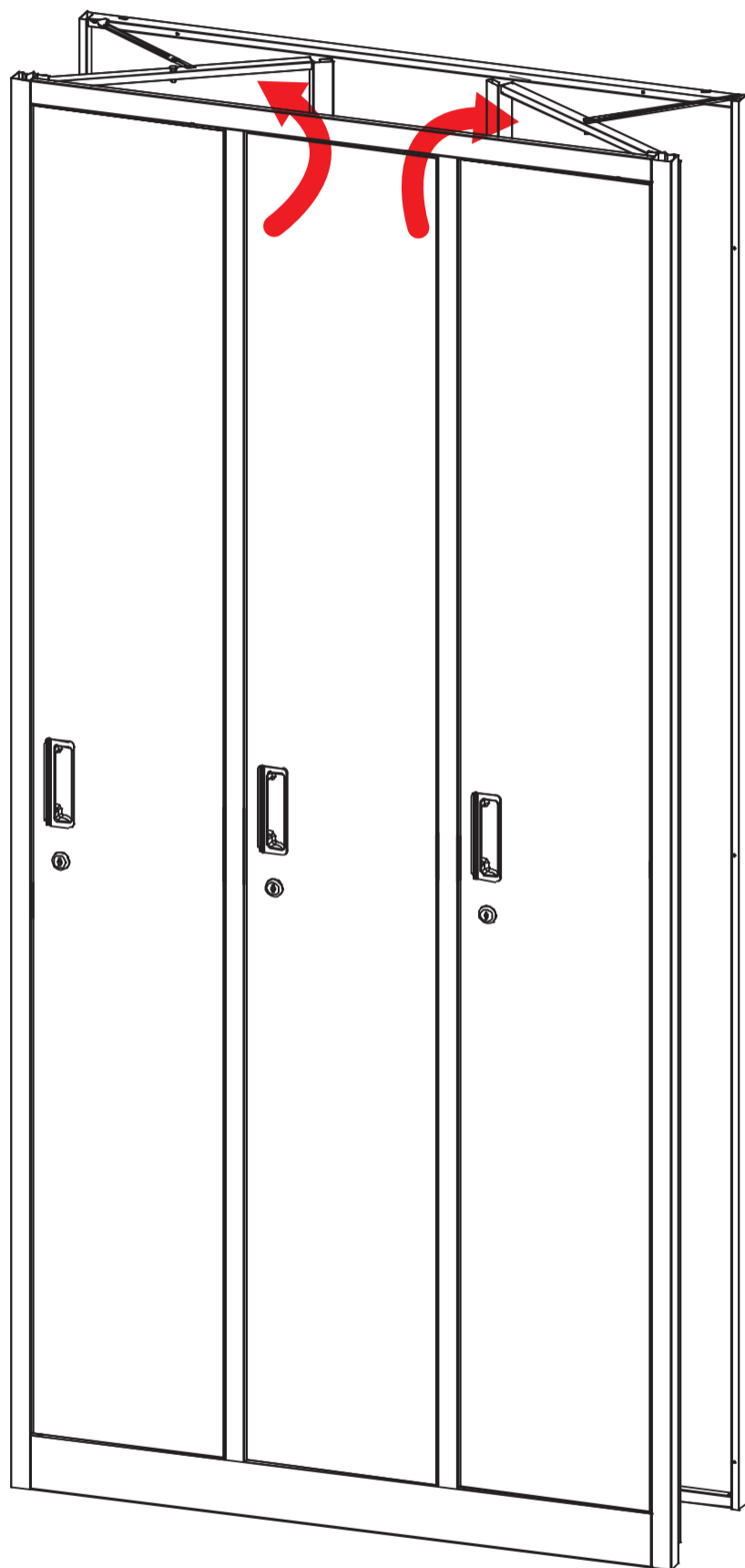

ARMADO FÁCIL PASO 2 · FIJACIÓN BASE

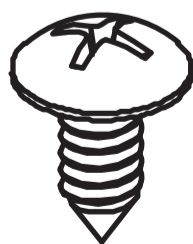
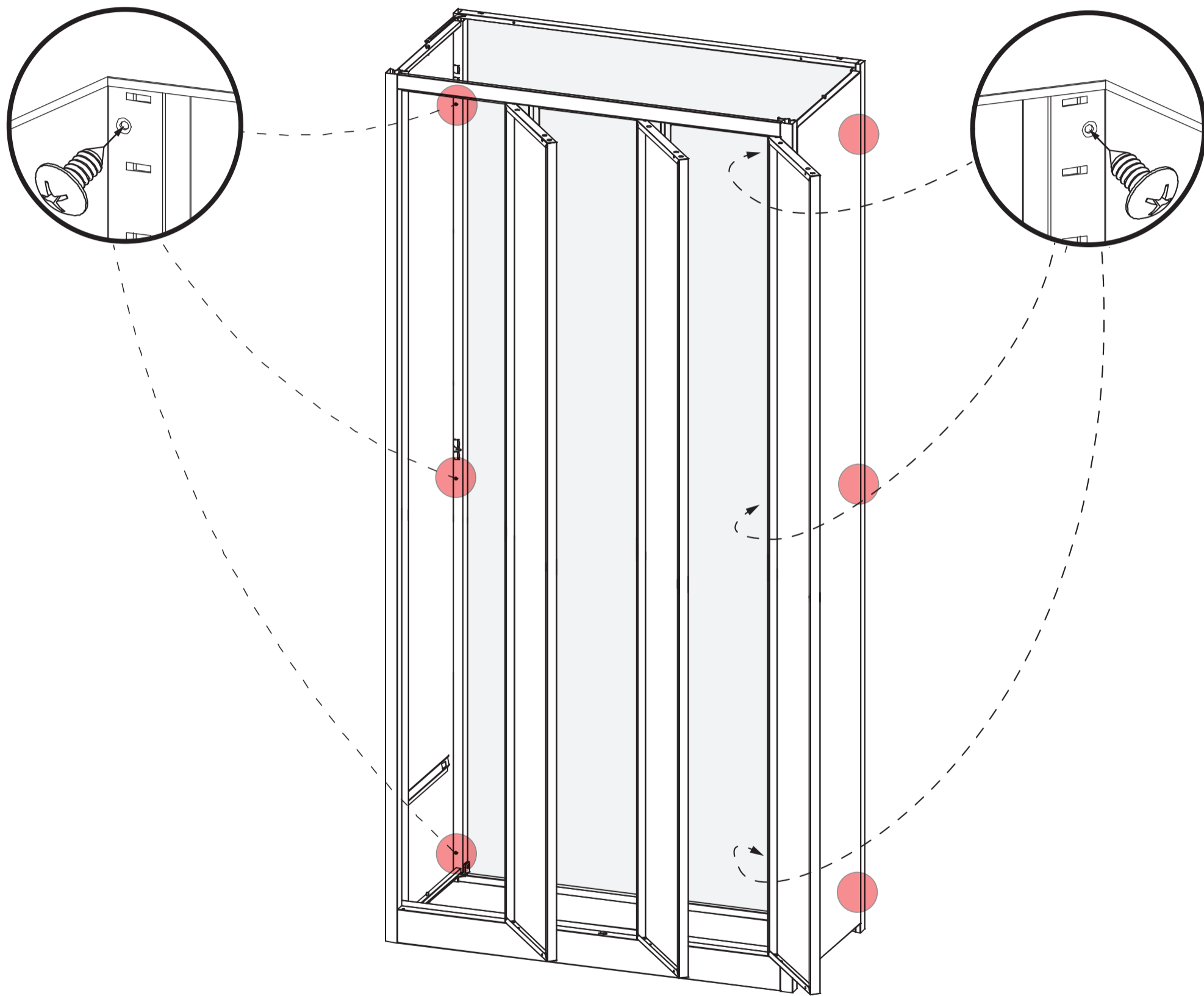

x6
Tornillo "A"

ARMADO FÁCIL PASO 3 · TAPA INFERIOR

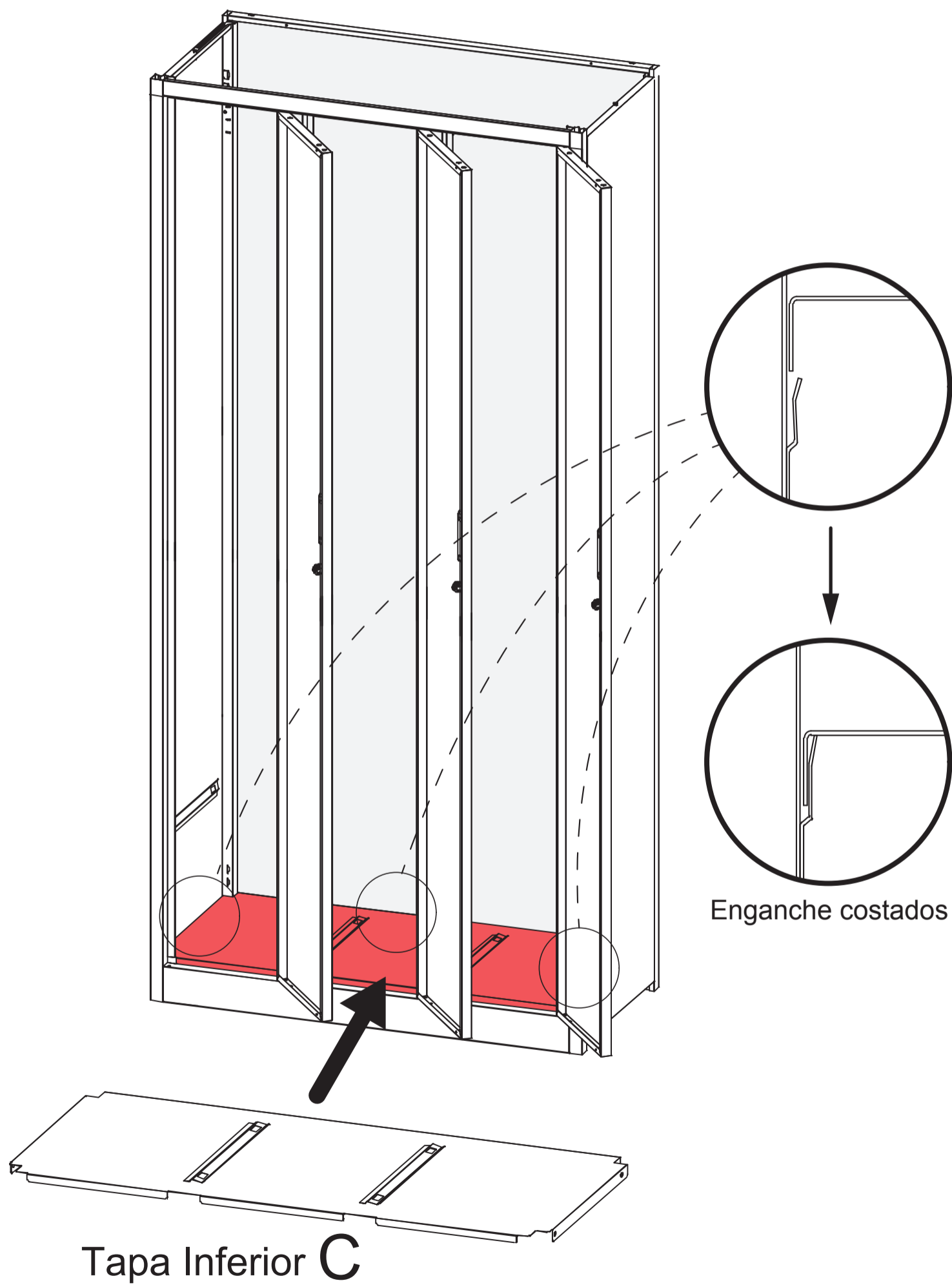

ARMADO FÁCIL PASO 4 · TAPA SUPERIOR

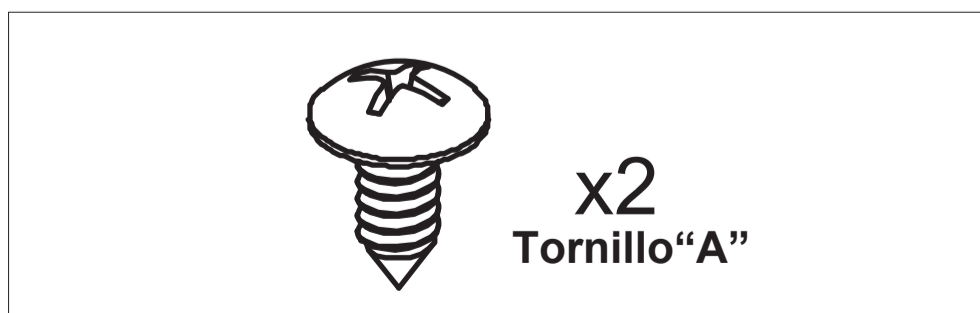
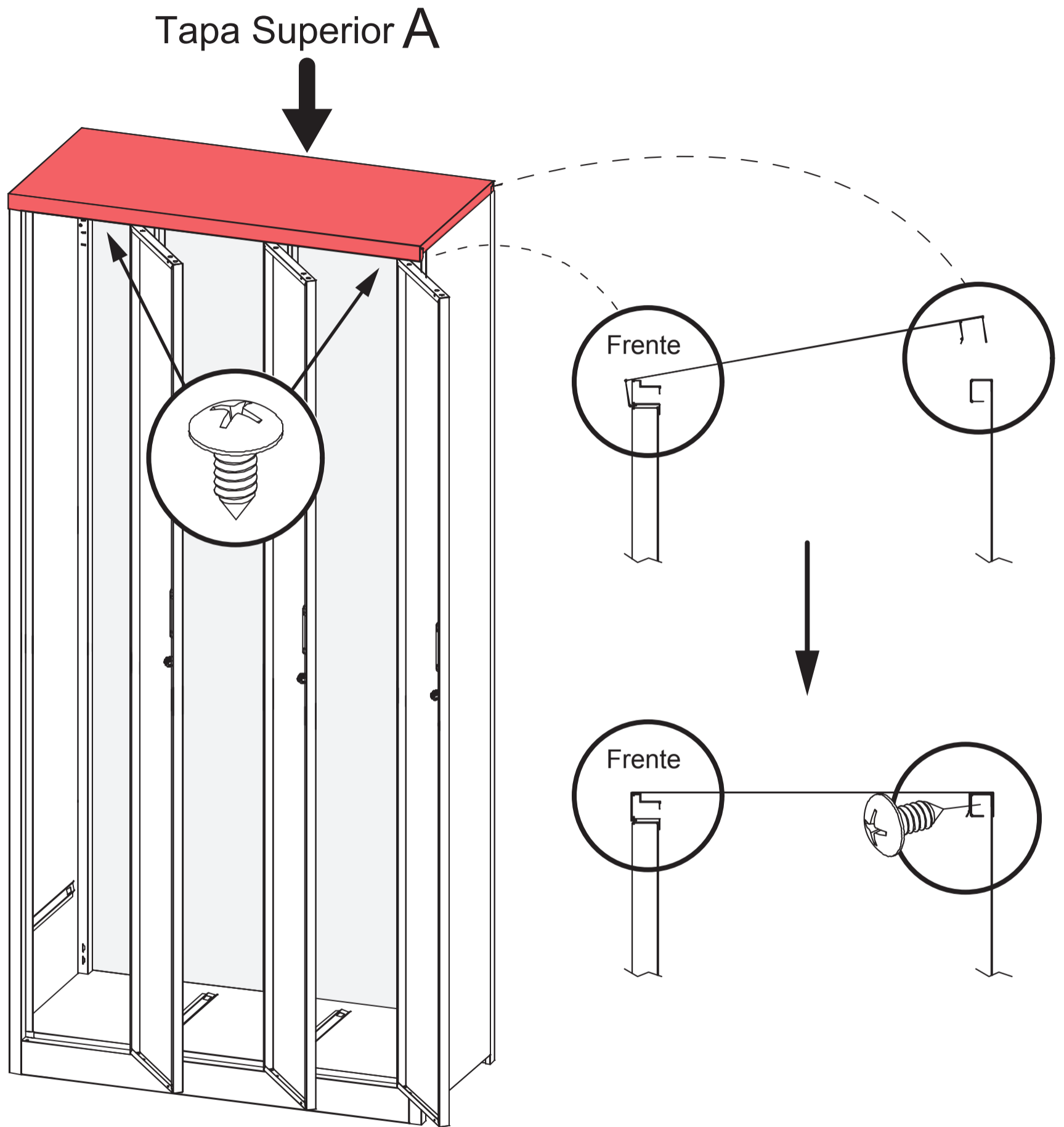

ARMADO FÁCIL PASO 5 · SEPARACIÓN VERTICAL

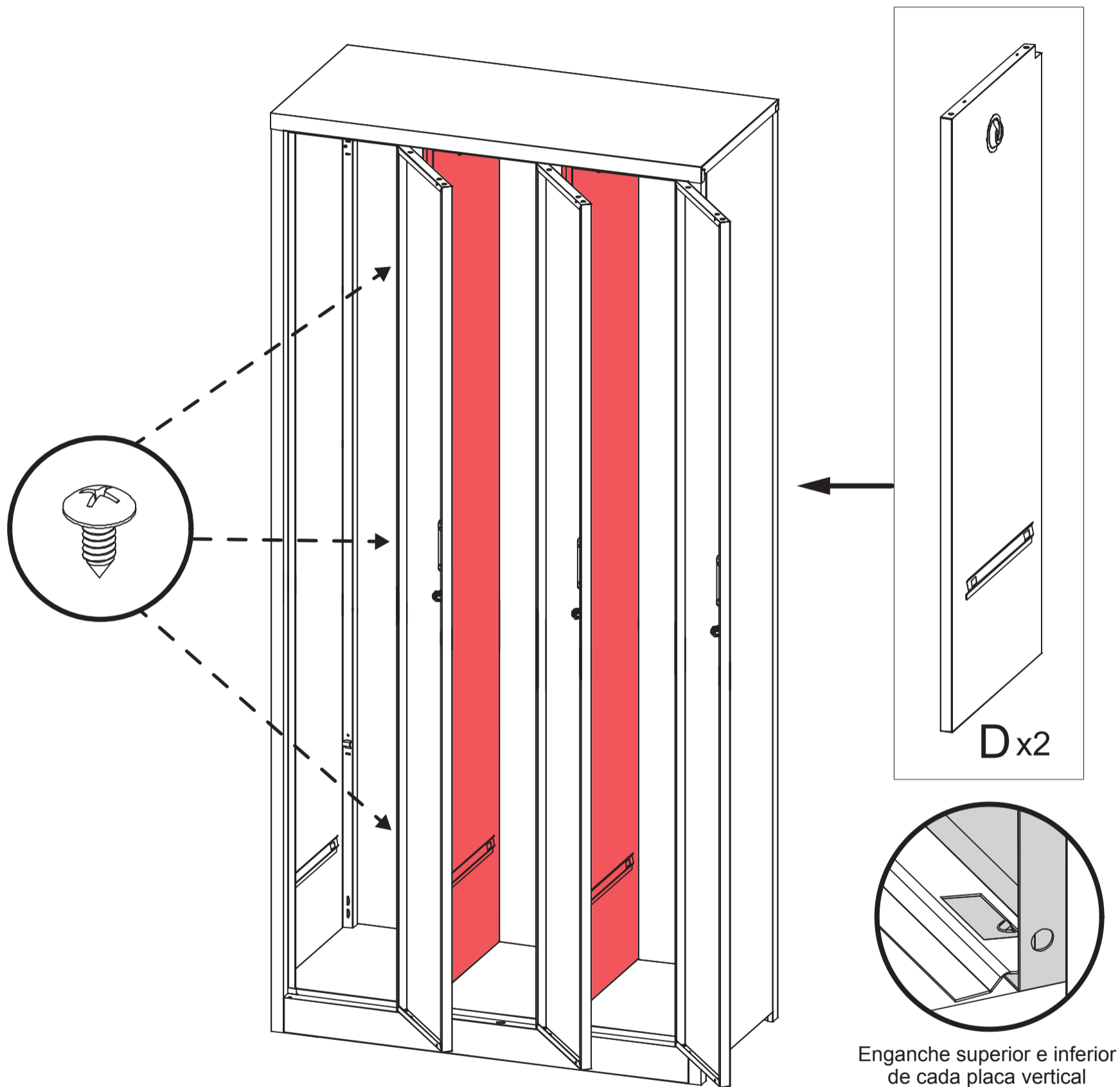

x6
Tornillo "A"

ARMADO FÁCIL PASO 6 · BARRAS Y BANDEJAS

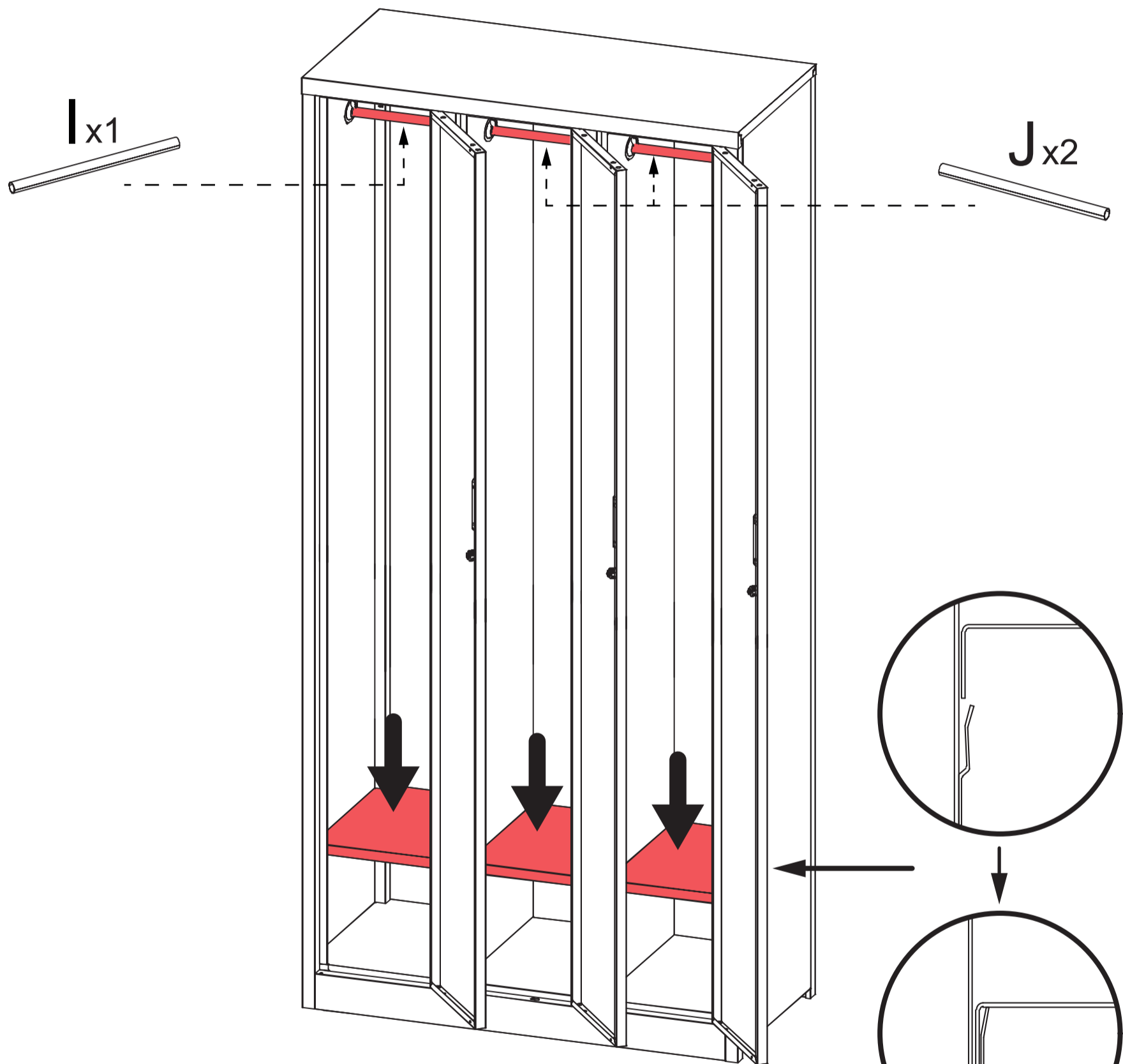

Bandejas



Izquierda



Centro



Derecha

ARMADO FÁCIL PASO 7 · SOPORTE PIE DE ALTURA

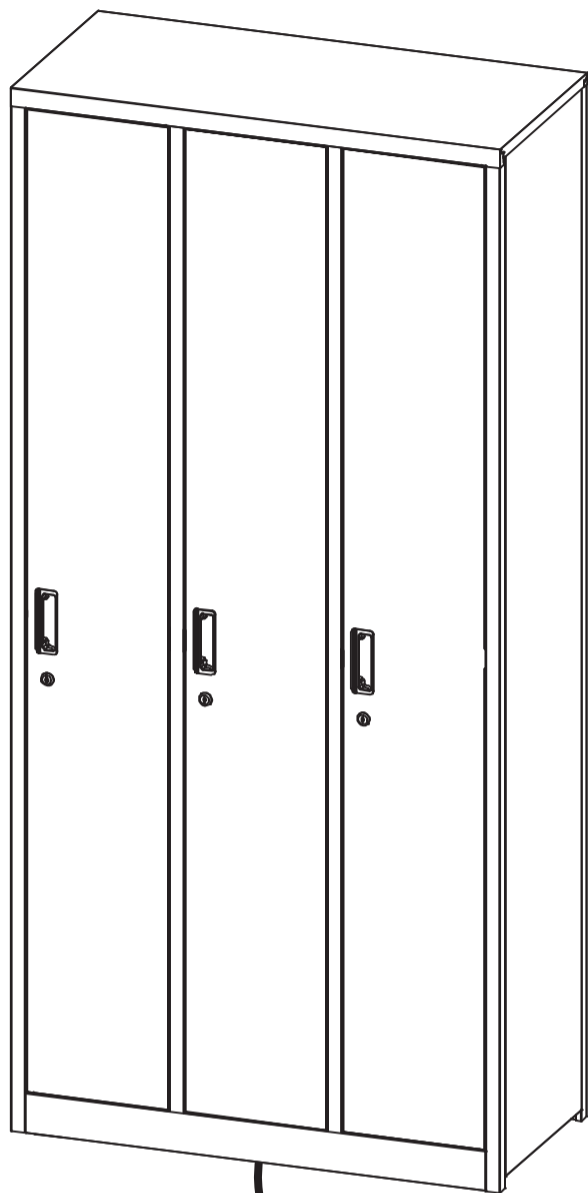

Zona Inferior

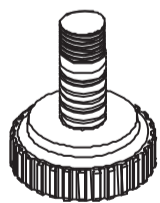
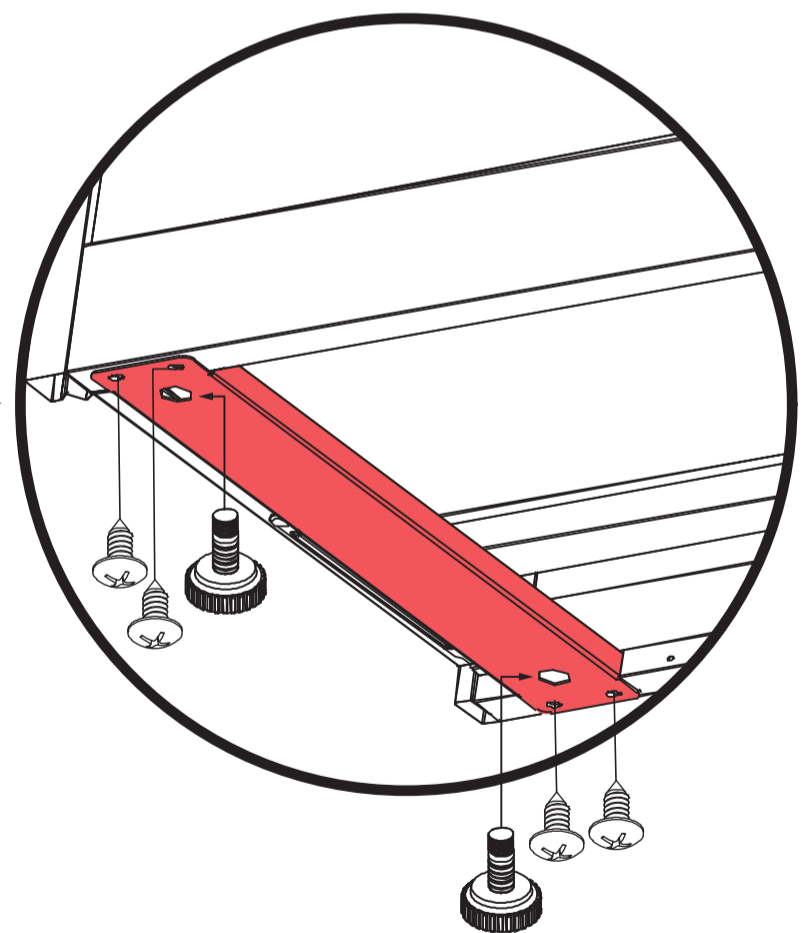

x4

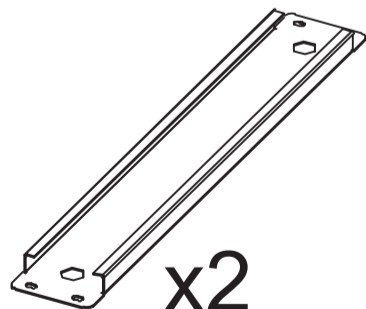

x2

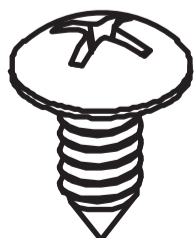

x8
Tornillo "B"

ARMADO FÁCIL

