

# ARMADO FÁCIL

MODELO AF3-02

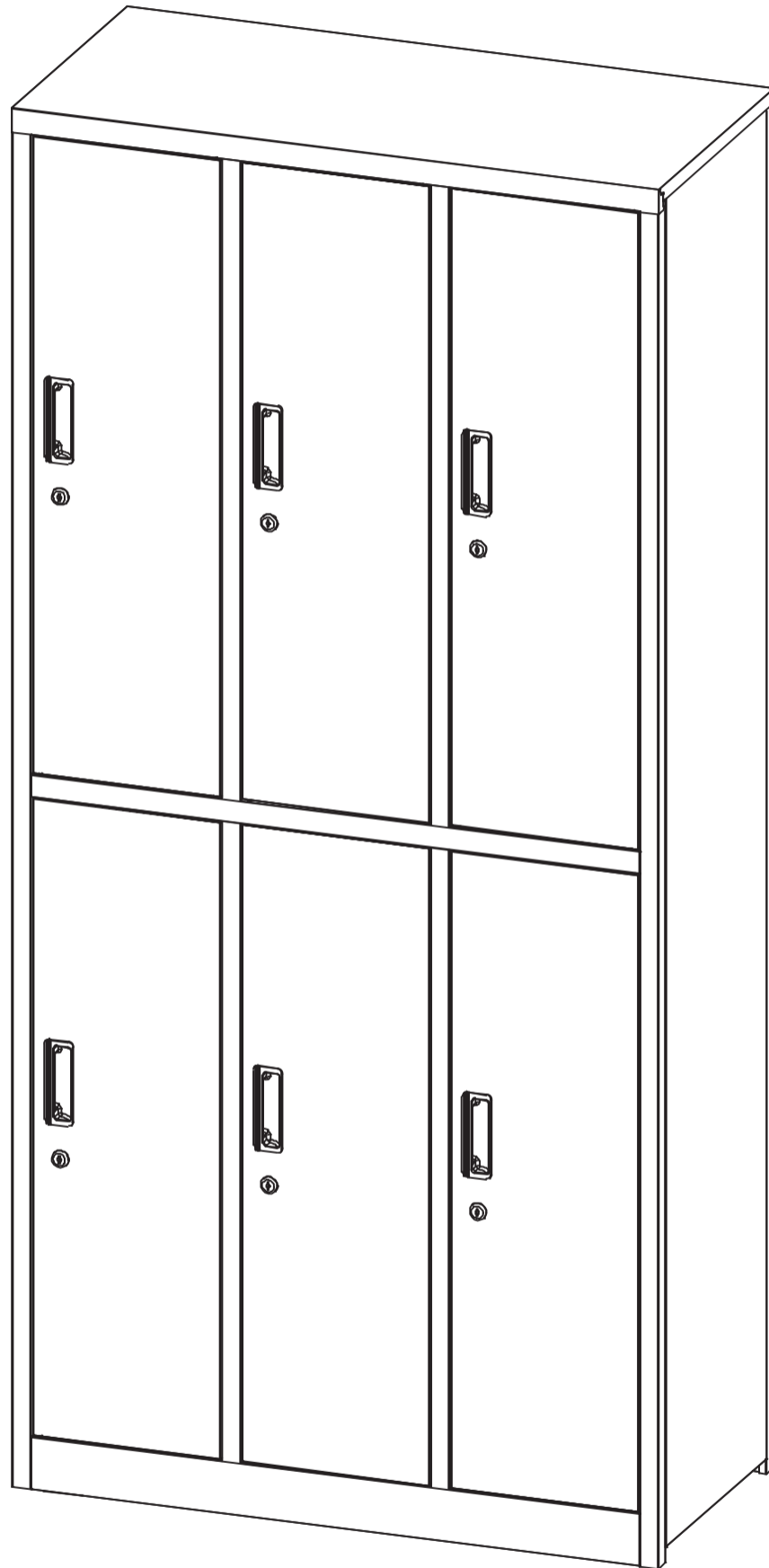

Herramientas necesarias:

**Atornillador de Cruz  
(no incluido)**

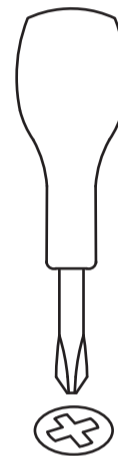

## **¡Precaución!**

Para evitar volcamiento del mueble no debe sobrecargarse en bandejas/compartimentos superiores.

Para evitar volcamiento puede fijarse a la pared (no se incluyen herramientas ni tornillos de fijación).

Este mueble debe ser armado por un adulto. En caso de duda, busca asesoramiento profesional. Lee y sigue cada paso de las instrucciones cuidadosamente.

# ARMADO FÁCIL LISTA DE COMPONENTES

Tapa Superior (x1)



Tapa Central (x1)  
Con ranuras en bandeja

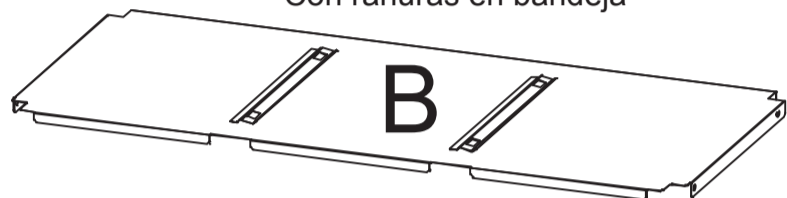

Tapa Inferior (x1)  
Con ranuras en bandeja



Bandejas



Izquierda  
(Grande)  
x2

Central  
x2

Derecha  
x2

Barras

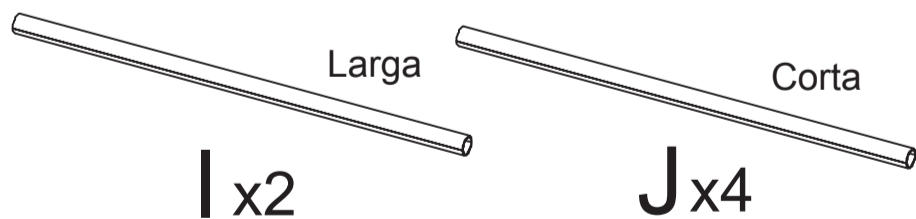

I x2

J x4

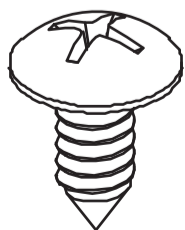

x16  
Tornillo "A"

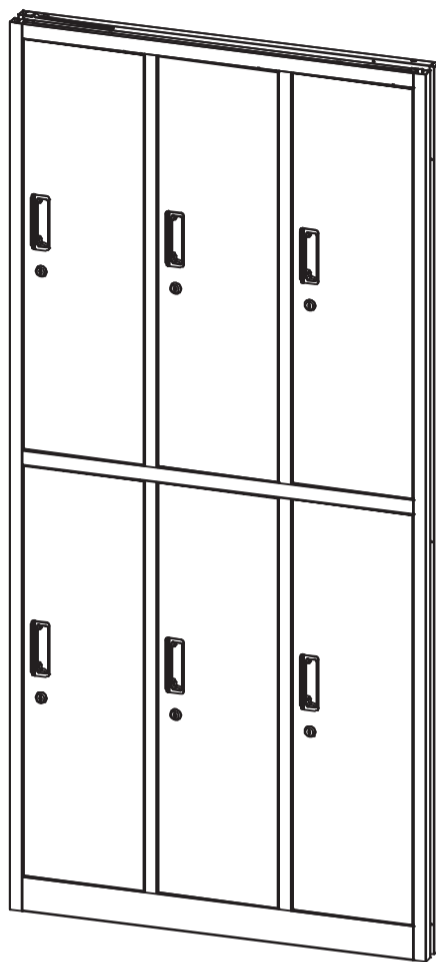

x1

Soporte  
pie de altura

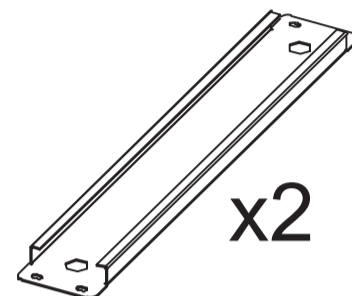

x8  
Tornillo "B"

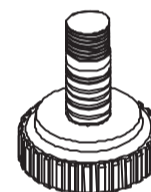

x4

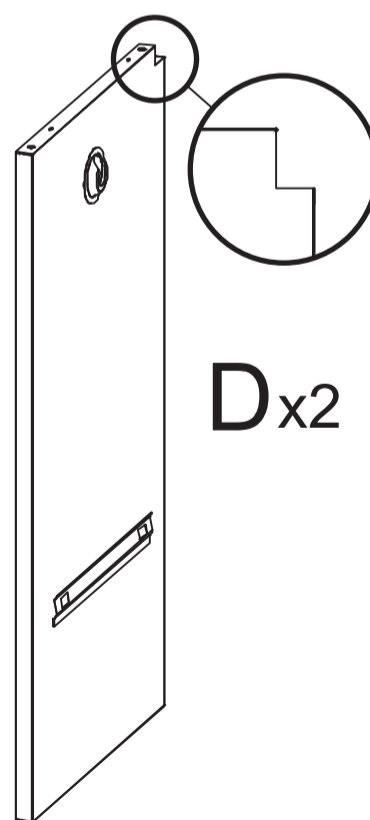

D x2

Placa vertical  
superior (corta)

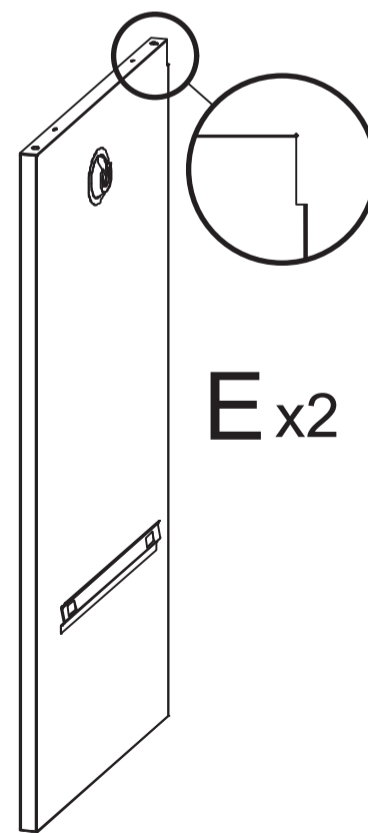

E x2

Placa vertical  
inferior (larga)

# ARMADO FÁCIL PASO 1 · APERTURA

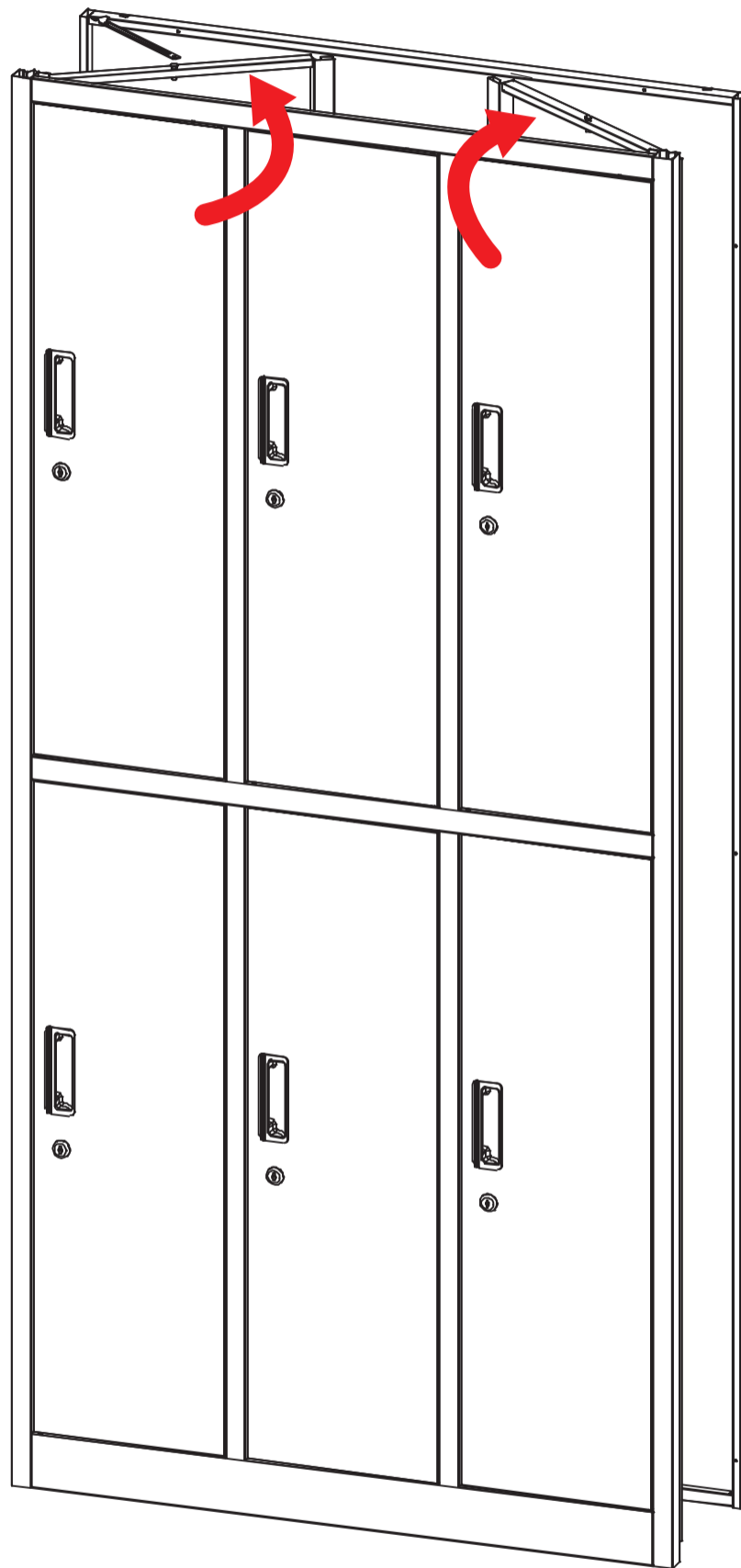

# ARMADO FÁCIL PASO 2 · FIJACIÓN BASE

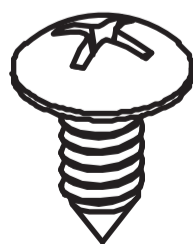
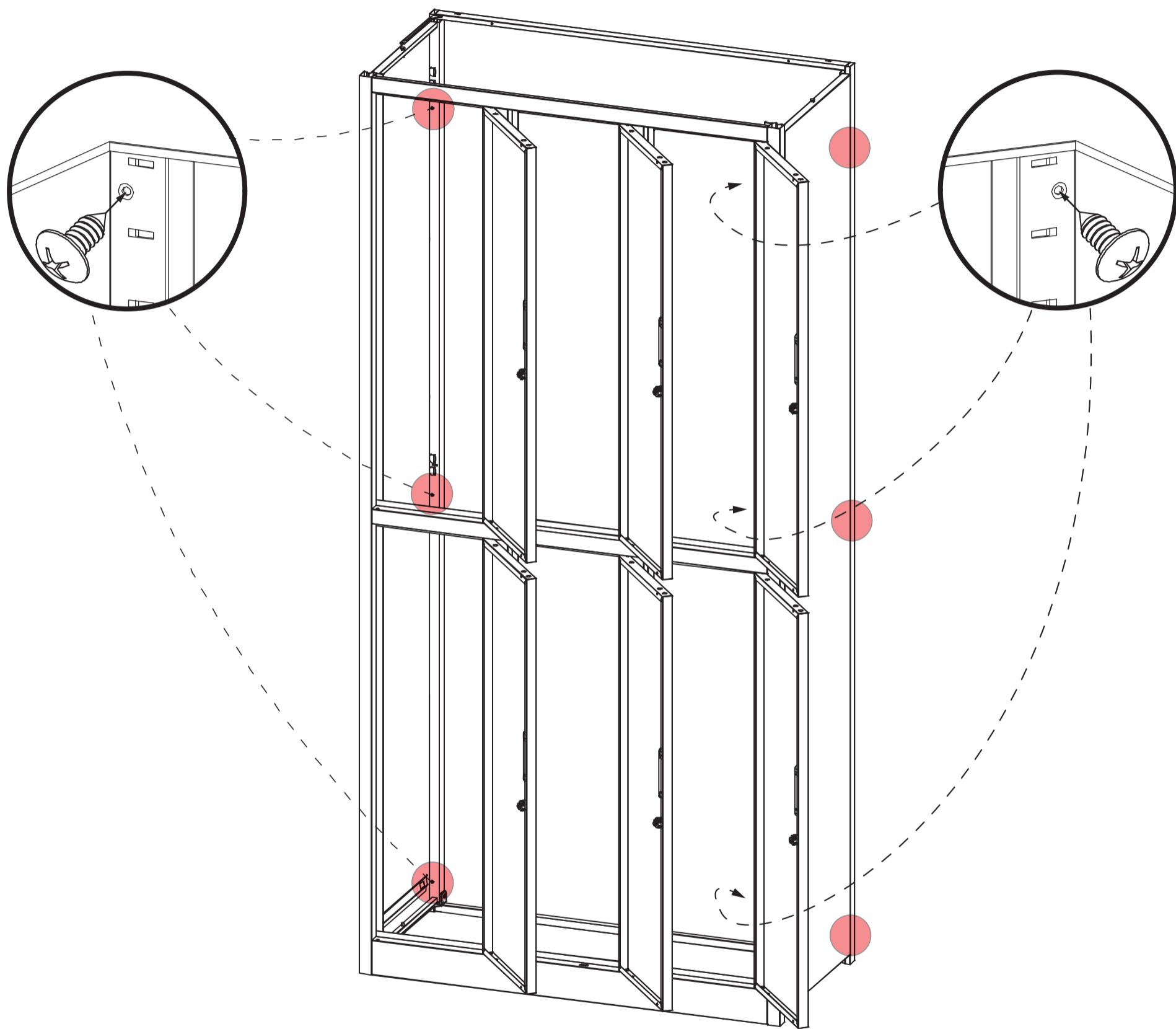

x6  
Tornillo "A"

# ARMADO FÁCIL PASO 3 · TAPAS CENTRAL E INFERIOR

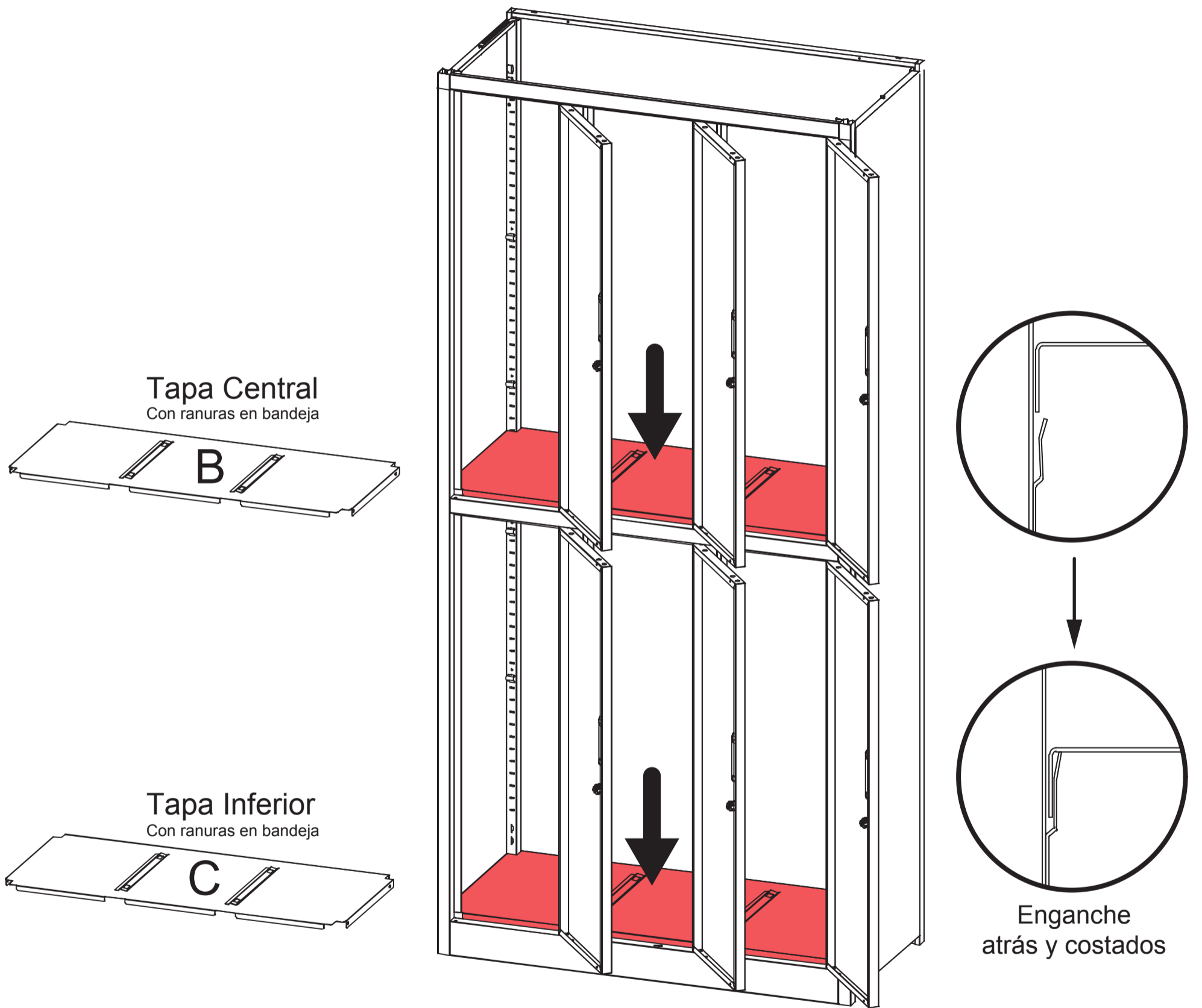

# ARMADO FÁCIL PASO 4 · TAPA SUPERIOR

Tapa Superior A

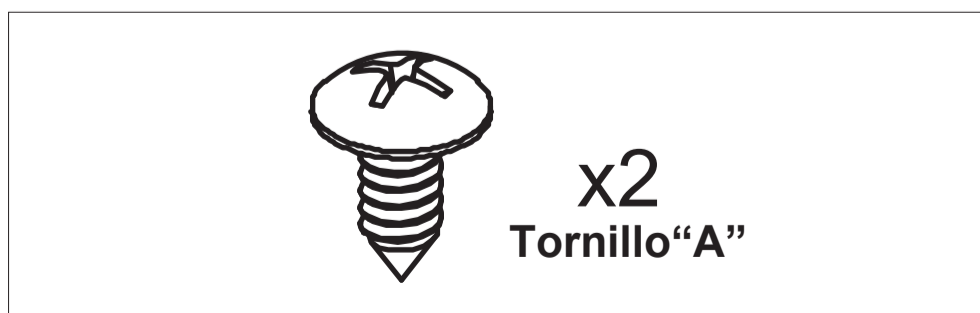
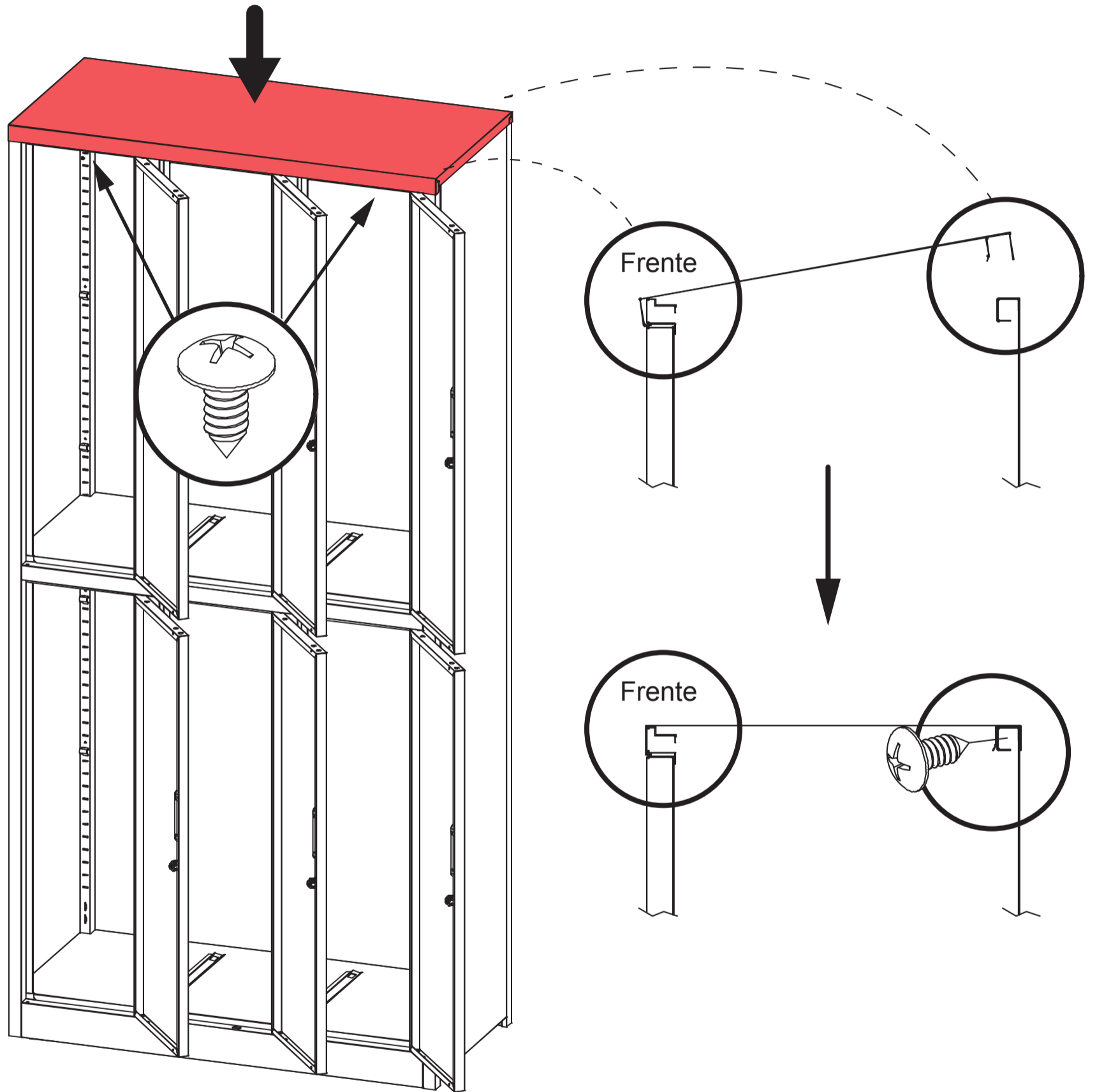

# ARMADO FÁCIL PASO 5 · SEPARACIÓN VERTICAL

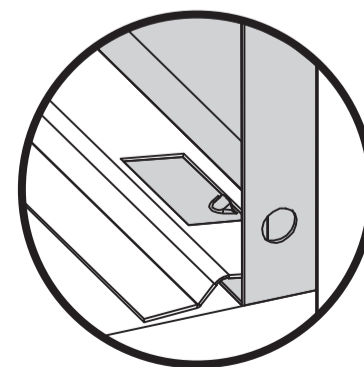
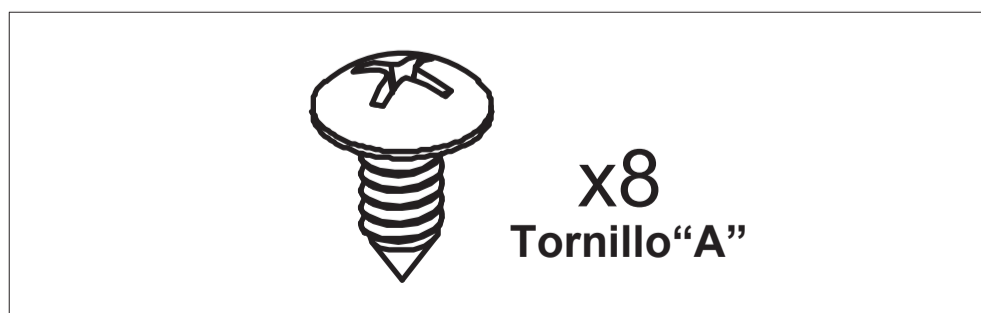
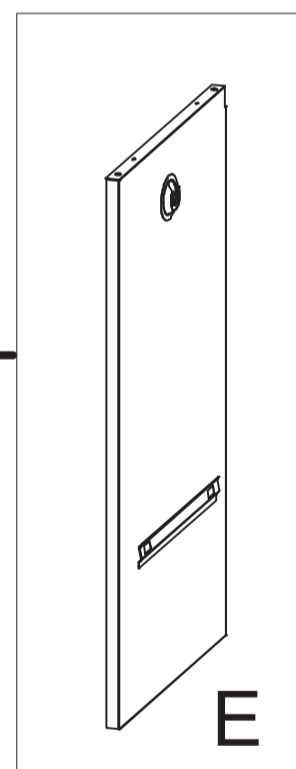
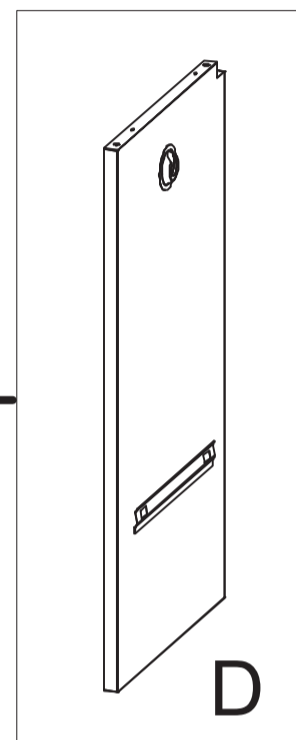
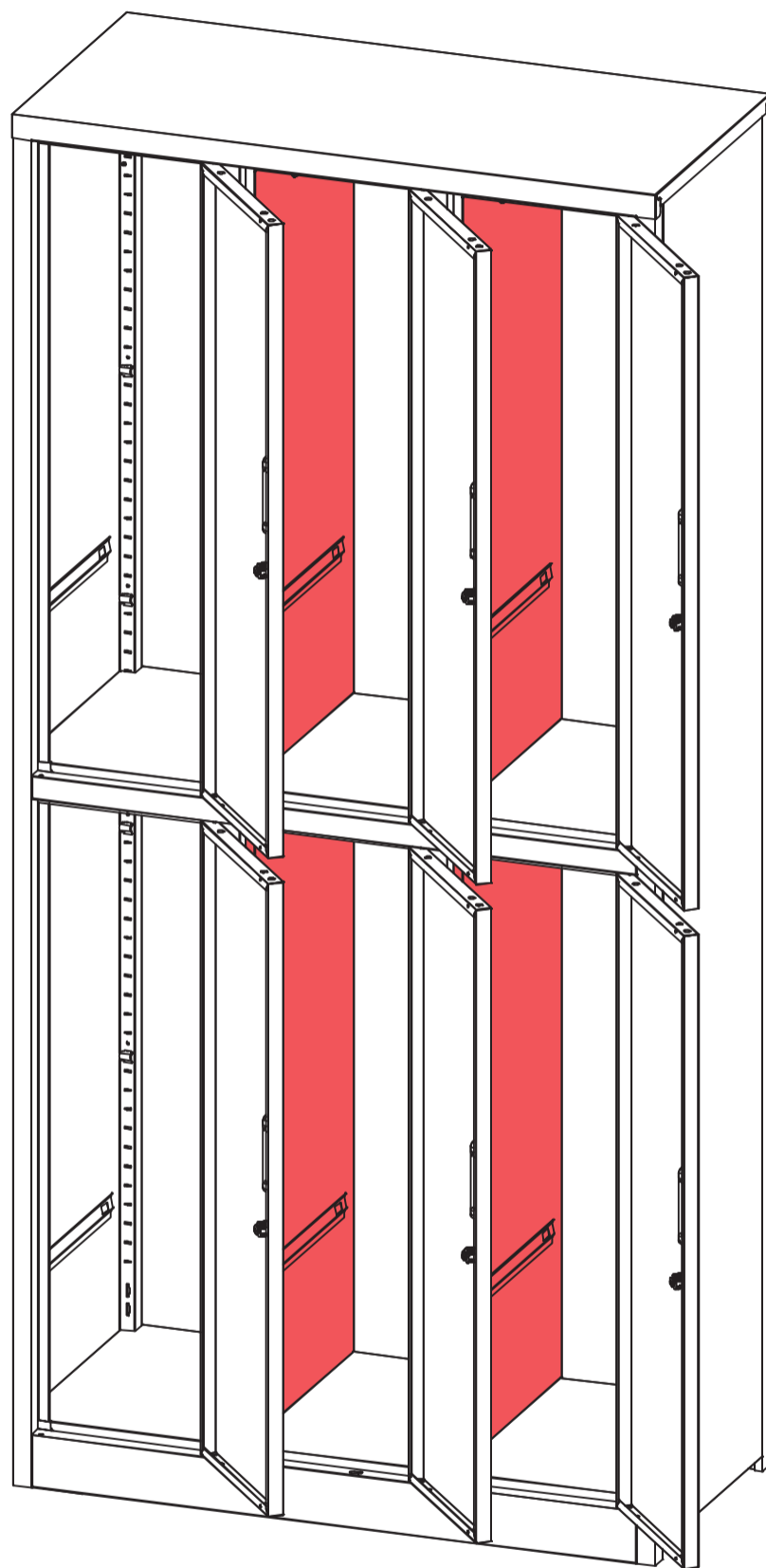
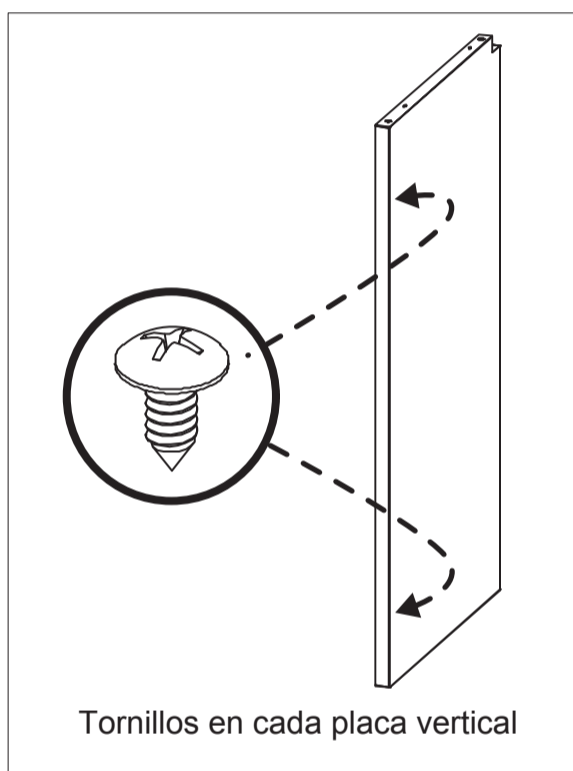

Enganche superior e inferior de cada placa vertical



# ARMADO FÁCIL PASO 6 · BARRAS Y BANDEJAS

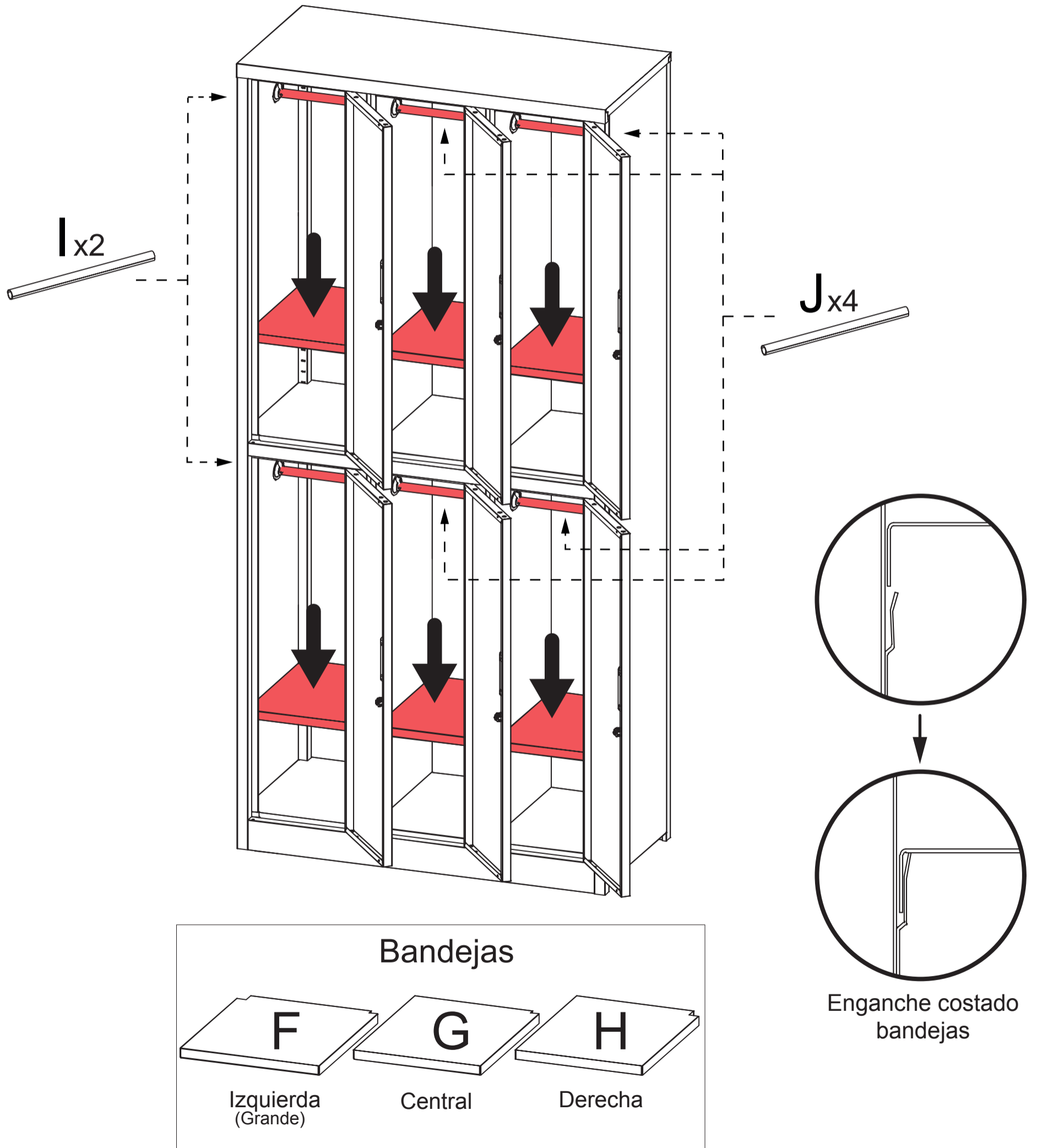

# ARMADO FÁCIL PASO 7 · SOPORTE PIE DE ALTURA

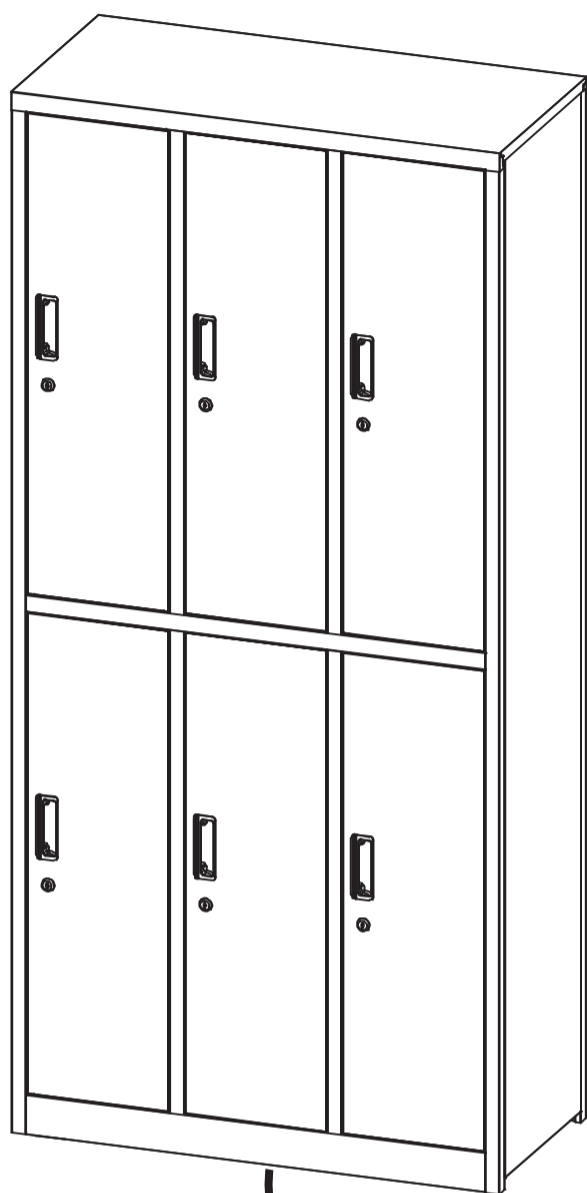

Zona Inferior

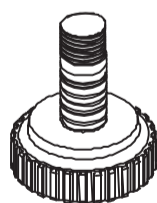
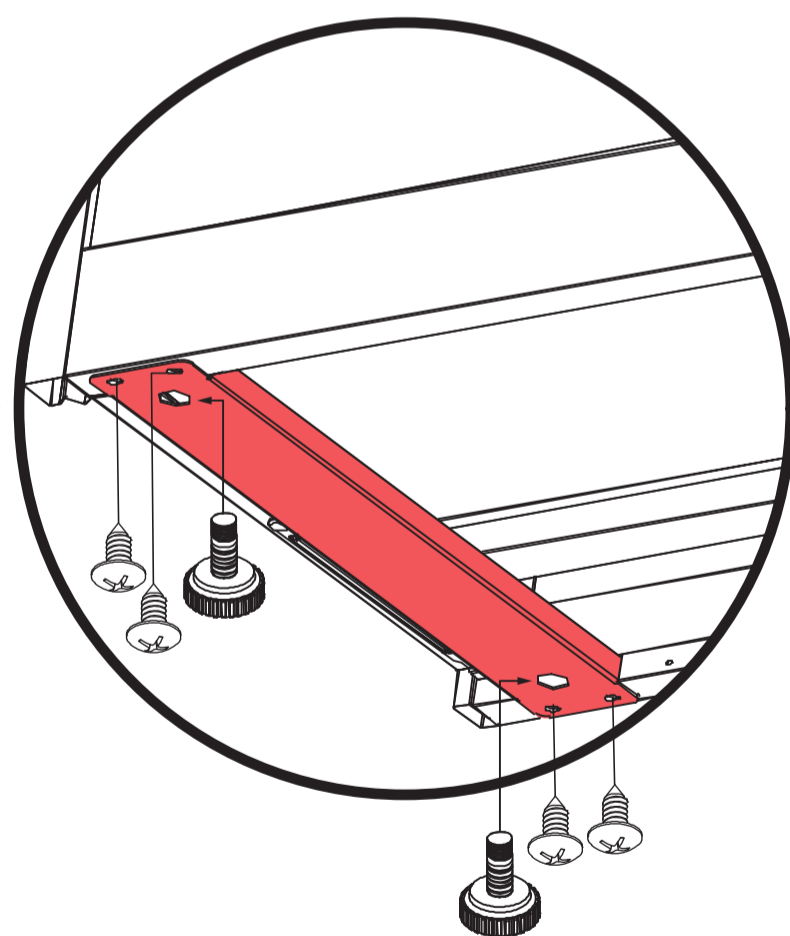

x4

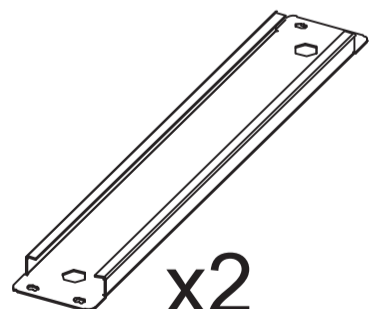

x2

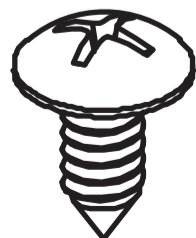

x8  
Tornillo "B"

**ARMADO FÁCIL**

